



Feel the Difference®

Assembly Instructions

Avonlea Garden Bench — Page 1

Tools Needed: hammer, 7/16" wrench, #2 square bit screw driver or power driver, No drilling is required. All the necessary holes are predrilled.



Parts

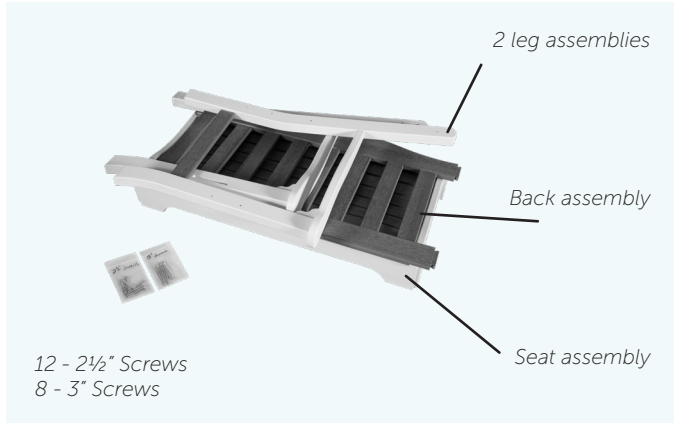

Step 1B — Fasten left leg assembly

2 1/2" Screws, right leg assembly

B

NOTE: The slats in the back assembly are designed with a larger setback on the front facing side, and a smaller setback from the rear facing side.

Position the seat back so that the larger slat setback is facing forward and insert it into the holes of the left arm assembly. Use a rubber mallet to tap the back and seat assembly tightly into the joints. Carefully rotating the chair to access the 6 pre-drilled holes on the outside of the left arm assembly, fasten the back assembly and seat assembly using 2 1/2" screws through the holes.

Step 1A — Fasten left leg assembly

2 1/2" Screws, left leg assembly, back assembly, seat assembly

A

A. Lay the parts on a protected surface such as cardboard or blankets to assemble them. Position the seat assembly so that the tag shows on the backside of the bench. Align the seat assembly with the holes in the left arm assembly and insert the seat assembly into the left arm assembly.

Continued on back



Feel the Difference®

Assembly Instructions

Avonlea Garden Bench — Page 2

Step 2 — Fasten right leg assembly

3" screws, seat assembly

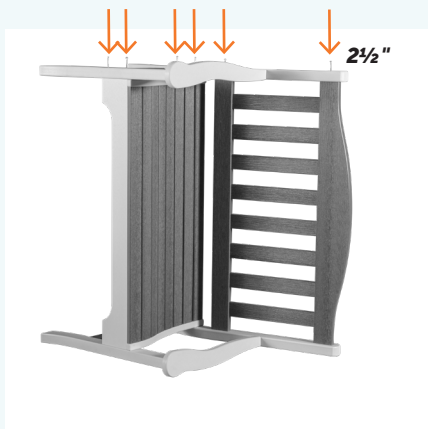

Align the holes of the right leg assembly with the seat assembly and back assembly. Use a rubber mallet to tap the right arm assembly tightly into the joints. Fasten the right arm assembly to the back assembly and skirts using 2 1/2" screws in the 6 pre-drilled holes.

Step 3 — Fasten seat assembly

3" screws, seat assembly



Accessing the underside of the bench, fasten the seat assembly with eight 3" screws in the pre-drilled holes in each corner.



Congratulations!
Your **Avonlea Garden Bench**
is ready to enjoy!