



Feel the Difference®

Assembly Instructions

Avonlea Garden Chair — Page 1

Tools Needed: #2 square bit screw driver or power driver, No drilling is required.
All the necessary holes are predrilled.



Parts

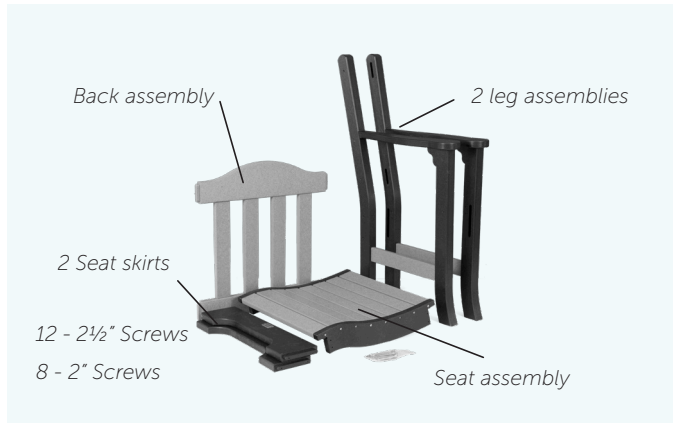

Step 2 — Fasten right leg assembly

2 1/2" Screws, right leg assembly

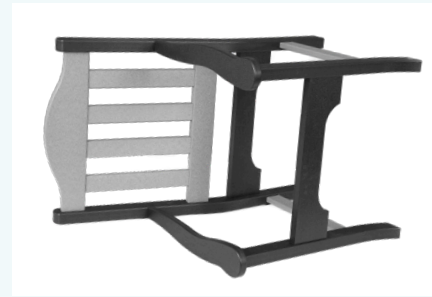

Place the right leg assembly on top. Align the holes of the right leg assembly with the skirts and chair back. Use a rubber mallet to tap the right arm assembly tightly into the joints. Fasten the right arm assembly to the back assembly and skirts using 2 1/2" screws in the 6 pre-drilled holes.

Step 1 — Fasten left leg assembly

2 1/2" Screws, left leg assembly, back assembly, seat skirts

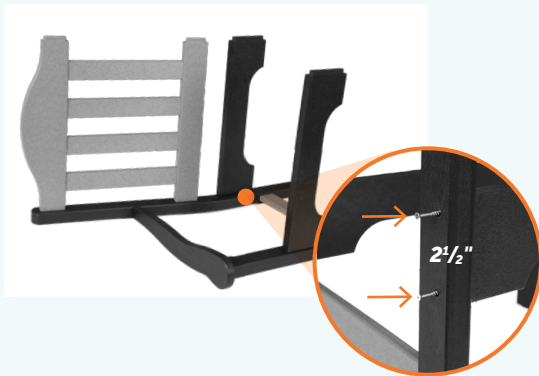

"NOTE: The slats in the back assembly are set back with a larger setback on the front facing side, and a smaller setback from the back facing side.

Place the parts on a protected surface such as cardboard or blankets to assemble them. Position the seat back so that the larger setback is facing forward and insert it into the left arm assembly. Position the skirts so that the tag is facing the back of the chair and insert them into the left arm assembly. Use a rubber mallet to tap the back assembly and skirts tightly into the joints. Carefully rotating the chair to access the 6 pre-drilled holes on the outside of the left arm assembly, fasten the back assembly and skirts using 2 1/2" screws through the holes.

Step 3 — Fasten seat assembly

2" screws, seat assembly



Lay the seat assembly, resting the front and back on the seat skirts. Fasten the seat assembly to the skirts using 2" screws in the 8 pre-drilled holes.

Continued on back



Feel the Difference®

Assembly Instructions

Avonlea Garden Chair — Page 2



Congratulations!
Your **Avonlea Garden Chair**
is ready to enjoy!