



Assembly Instructions

High Tide Rocker (HI-Ro) — Page 1

Tools Needed: #2 square bit screw driver or power driver, rubber mallet.



Parts

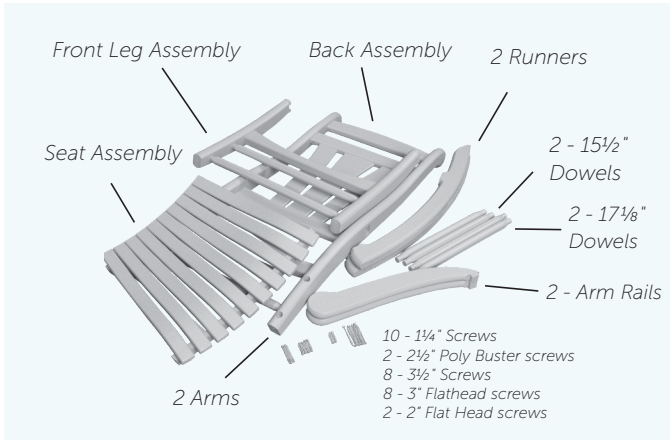

Step 2 — Insert Seat

Seat, 2- 1/4" Flathead Screws

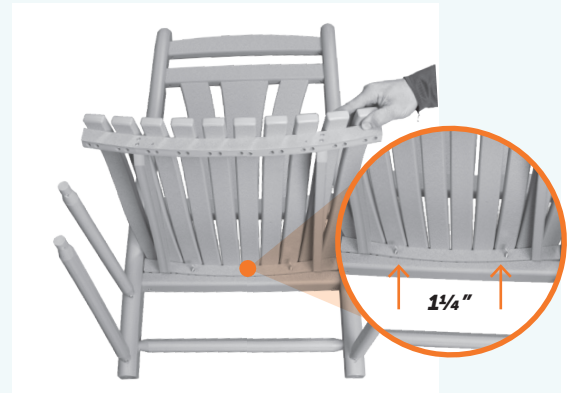

Now, set the seat into the notch on the back and attach with five 1/4" flathead screws.

Step 1 — Assembling the Back

Back Assembly, 2- 16 1/4" Dowels, 2- 17 7/8" Dowels, 4- 3" Flathead Screws

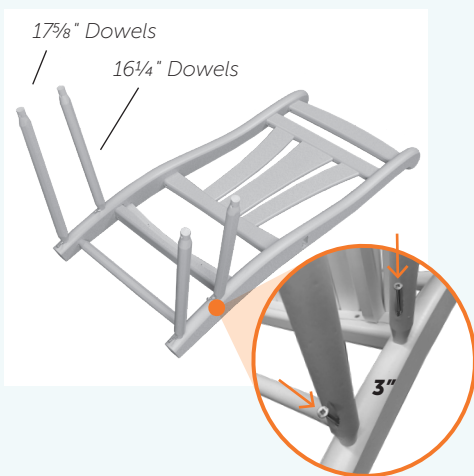

First, lay back assembly on a blanket or clean, soft surface. Next, insert dowels with the predrilled holes facing the bottom of the chair, angled very slightly toward the center of the chair. Now, attach using four 3" flathead screws in predrilled holes.

Step 3 — Front Leg Assembly

Front Leg Assembly, 4- 3" Flathead Screws, 3- 1/4" Flathead Screws

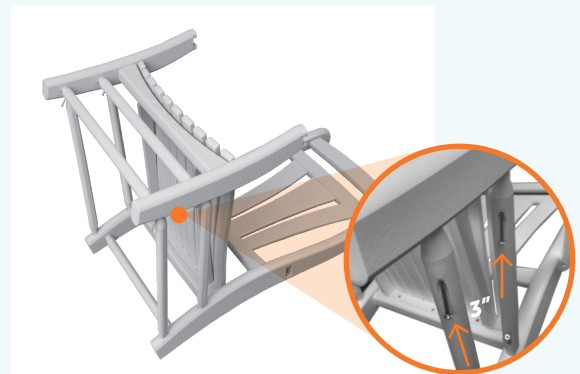

Place the front leg assembly on top, aligning each part with its mortise. Now, tap into place with a rubber mallet. Next, attach the dowels with 4- 3" Flathead Screws. Then attach front of seat with 5- 1/4" Flathead screws.

Continued on back

Step 4 — Attaching the Runner

8- 3½" Flathead Screws, 2 Runners



Next, attach the two runners using four 3½" flathead screws in each runner.

Step 5 — Attaching the Arm Rest

2½" Poly Buster Screws, Support Rail, Tabletop for spacing

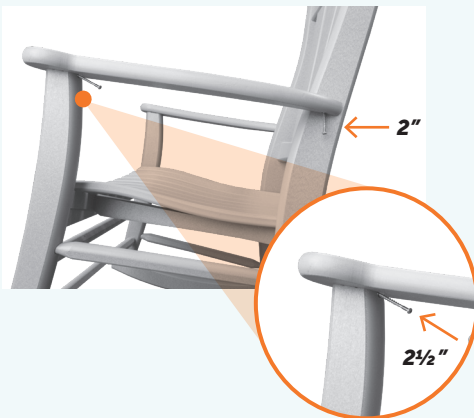

Now, insert the two arms into their tenons. Finally, attach using the 2½" Poly Buster screws at the front of the arm and 2" Poly Buster screws at the back.

Congratulations!
Your **High Tide Rocker**
is ready to enjoy!

