



Feel the Difference®

# Assembly Instructions

## SeaAira Child's Chair

**Tools Needed:** #2 square bit screw driver or power driver, No drilling is required.  
All the necessary holes are predrilled.



### Parts

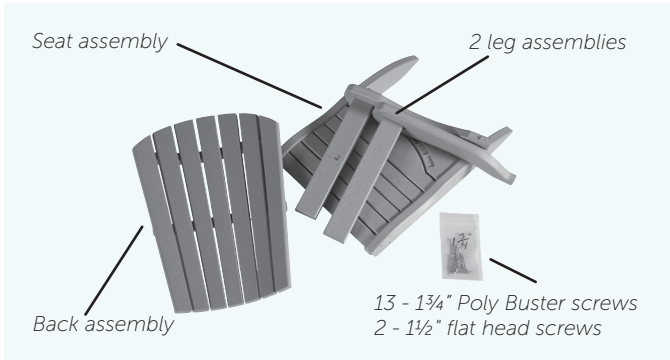

### Step 2 — Attach leg assemblies to seat assembly

6 - 1 3/4" Poly Buster screws, 2 - 1 1/2" flat head screws,  
2 leg assemblies

A



A. Fasten the front of the leg assembly to the seat assembly, aligning the pilot holes and fastening together using the 1 3/4" poly buster screws.

### Step 1 — Attach back assembly

7 - 1 3/4" Poly Buster screws, back assembly, seat assembly

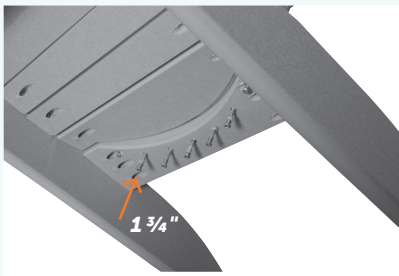
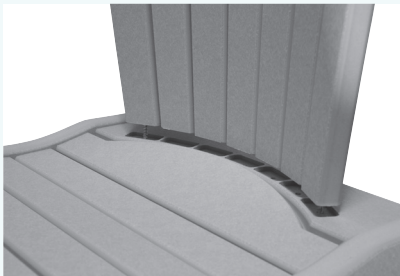

Lay the parts on a protected surface such as cardboard or blankets for assembly. Align the back assembly to be attached to the seat assembly; lining up the back slats of the back assembly with the slat pockets on the seat assembly. Attach the two assemblies using 1 3/4" poly buster screws.

Continued on back



Feel the Difference®

# Assembly Instructions

SeaAira Child's Chair — Page 2

## Step 2 — Continued

6 - 1 $\frac{3}{4}$ " Poly Buster screws, 2 - 1 $\frac{1}{2}$ " flat head screws,  
2 leg assemblies

**B**



B. Align the pilot holes in the back of the leg assembly with the pilot holes on the back assembly. Use 1 1/2" flat head screws to fasten the back of the arm to the seat back.

Repeat steps a & b for the second leg assembly.



Congratulations!  
Your **SeaAira Child's Chair**  
is ready to enjoy!