



Feel the Difference®

# Assembly Instructions

## SeaAira Chaise Lounge — Page 1

**Tools Needed:** hammer, 7/16" wrench, #2 square bit screw driver or power driver, punch  
No drilling is required. All the necessary holes are predrilled. Bolts fit snugly in the holes. You may need to use a hammer to drive the bolts through the holes.

Hardware shown for Chaise Lounge With Arms. Chaise Lounge Without Arms includes: (20) 1 3/4" screws, (2) 3" Lag Bolts, (4) Washers



### Parts

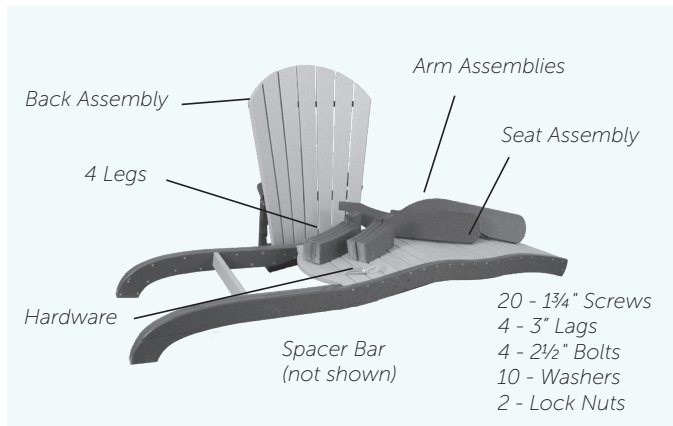

### Step 2A — Attach Back Assembly

Seat Assembly, Lag Bolts, Spreader Bar, Washers

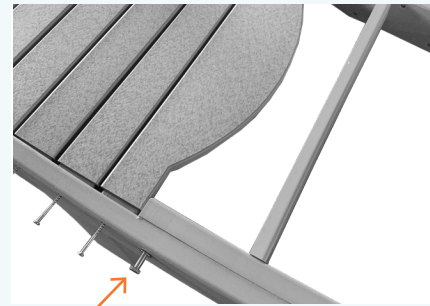

A. Flip the seat assembly so it is right-side-up and standing on the leg assemblies. Looking from the end of the seat assembly where the seat back will eventually go, insert the spreader bar about 3"-5" from the last slat, being sure to push the spreader bar so a gap of approximately 3/8"-1/2" is visible between the frame and the last slat. Place a washer on the lag bolt, and insert it into the pilot hole in the seat assembly where the last slat is. With the bolt barely through the pilot hole, carefully place a second washer on the lag bolt on the inside of the seat assembly.

### Step 1 — Attach Legs to Seat

Screws, Seat Assembly, Legs

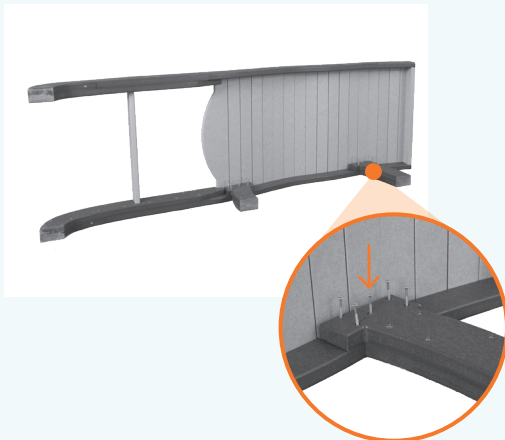

Place the seat assembly on a clean flat work surface. Align the pilot holes in the legs with the pilot holes in the rail of the seat assembly. Place five screws per leg.

### Step 2B — Attach Back Assembly

Lag Bolts, Washers, Spreader Bar, Back Assembly

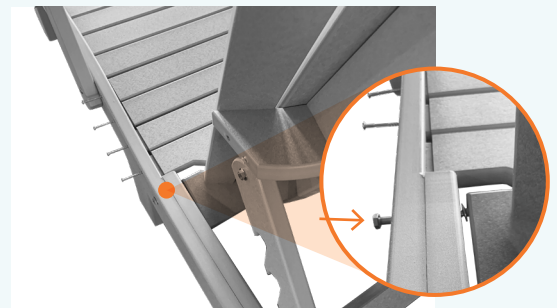

B. Insert the back assembly, being sure to match the pilot holes on the seat assembly with the pilot holes on the back assembly. Fasten 1 lag bolt. Begin fastening the second lag 1-2 turns. Remove the spreader bar, then finish tightening the second lag bolt on the other side.

Continued on back



Feel the Difference®

# Assembly Instructions

SeaAira Chaise Lounge — Page 2

## Step 3 — Tighten Slats

1 3/4" Screws, Seat Assembly

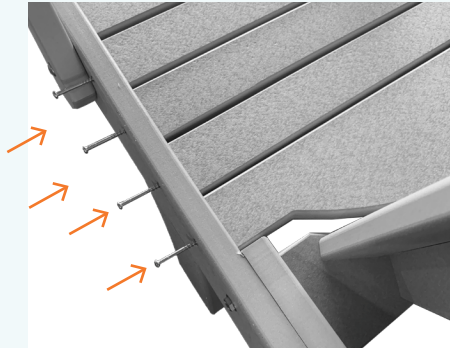

Using 4 - 2" screws, fasten the last 4 slats of the seat assembly using the pilot holes provided.

## Step 4 — Attach Arms

(Applicable for Models with Arms Only)

1 3/4" Screws, Seat Assembly

**A**

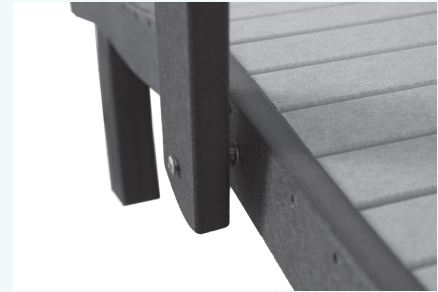

B. Place a washer on a lag bolt. Insert the lag bolt in the pilot hole located on the bottom of the arm assembly. Place another washer on the lag bolt. Align the arm assembly and lag bolt with the pilot hole in the Seat Assembly. Push the lag bolt through the pilot hole, and place a lock nut on the back side of the lag bolt. Tighten securely. Repeat on the other arm assembly.

**B**

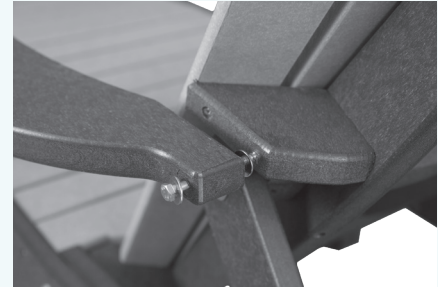

Place a washer on a lag bolt. Insert the lag bolt in the pilot hole located in the back of the arm assembly. Place another washer on the lag bolt. Align the arm assembly and lag bolt with the pilot hole in the Back Assembly, and tighten the lag bolt securely. Repeat on the other arm assembly.

Congratulations!  
Your **SeaAira Chaise Lounge**  
is ready to enjoy!

