



Feel the Difference®

Assembly Instructions

Zinn's Mill Rocker (ZI-Ro) — Page 1

Tools Needed: #2 square bit screw driver or power driver, rubber mallet.



Parts

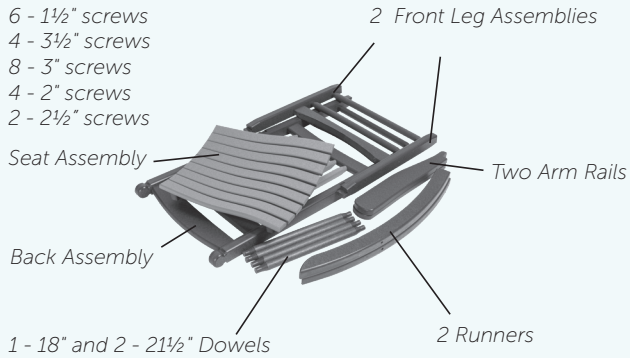

Step 2 — Attaching the Seat Assembly

Seat Assembly, 1½" Screws



Now, use the 1½" screws to attach the seat assembly to the back assembly.

Step 1 - Assembly of the Back

1 - 18" and 2 - 21½" Dowels, Back Assembly, 3" Screws.



First, lay down back assembly. Now insert each dowel into the correct mortise. Next tap with a rubber mallet for a tight fit. Finally, assemble using the 4 - 3" screws on each side.

Continued on back



Feel the Difference®

Assembly Instructions

Zinn's Mill Rocker (ZI-Ro) — Page 2

Step 3 — Attaching the Front Leg Assemblies

Two Front Leg Assemblies, 3" Screws



Use the 3" screws to attach the top front leg assemblies.

Step 5 — Arm Assembly

Leg and Arm Assembly, 4 - 2" Screws, 2 - 2½" Screws

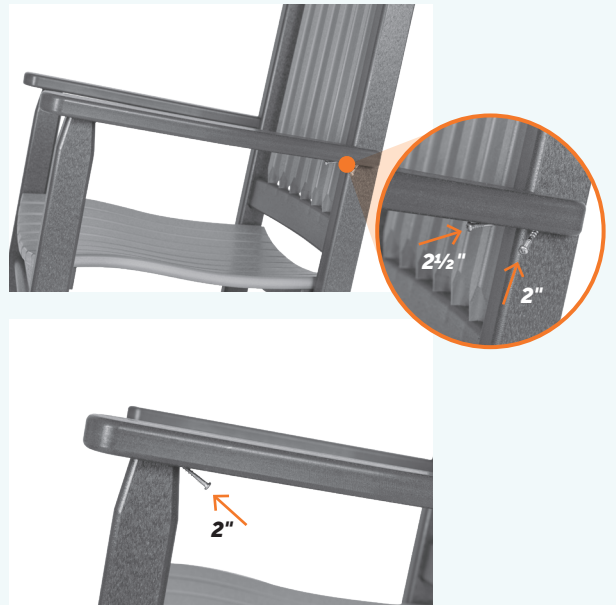

Insert each arm rail into the correct mortise. Tap with a rubber mallet for a tight fit. Lay the second arm rail on top. Align the parts with their mortises, and tap into place. Finally, finish by making sure all screws are tight.

Step 4 — Attaching the Runners

2 Runners, 3½" Screws



Now, use the 3½" screws to attach the 2 runners to the bottom of the chair legs.



Congratulations!
Your Zinn's Mill Rocker
is ready to enjoy!