



# FIREMASTER

OUTDOOR COUNTERTOP CHARCOAL GRILL  
Models 3324 and 3329

## INSTALLATION INSTRUCTIONS AND OWNER'S MANUAL



**INSTALLER:** Leave these instructions with consumer.  
**CONSUMER:** Retain for future reference.

**IMPORTANT:** READ THESE INSTRUCTIONS CAREFULLY BEFORE STARTING INSTALLATION OR USE.

### WARNINGS AND SAFETY CODES

**▲ WARNING:**  
Do not store or use gasoline or other flammable vapors and liquids, including propane cylinders, in the vicinity of this or any other appliance.

**▲ WARNING:**  
Improper installation, adjustment, alteration, service, or maintenance can cause injury or property damage. For proper installation, refer to the installation instructions. For assistance or additional information, consult a qualified professional service technician, or service agency.

**ONLY TO BE USED OUTDOORS**

**CODE REQUIREMENTS:** This grill must be installed in accordance with local codes and ordinances.

**WARNING:** All surfaces of the charcoal unit become **HOT** during use. Exercise caution when using this unit, especially when adding charcoal or cranking the charcoal pan up or down. Wear heat-resistant gloves as necessary.

Proper operation of your grill requires prompt and periodic maintenance. See the **SERVICING AND CLEANING** section for details.

Cooking Grid U.S.  
Patent Nos.  
D857,453  
D862,984

**GETTING STARTED**

INSTALLATION, OPERATION, AND SAFETY INFORMATION.....3  
ENCLOSURE REQUIREMENTS.....4  
    *ENCLOSURE PARAMETERS*.....4  
INSTALLATION REQUIREMENTS .....6  
    *OVERHEAD CONSTRUCTION REQUIREMENTS*.....6  
    *REAR WALL CLEARANCES*.....7  
DIAGRAMMATICAL REPRESENTATIONS OF OUTDOOR AREAS .....8  
MODEL SPECIFICATIONS .....9  
REPLACEMENT PARTS LIST .....10

**INSTALLATION**

INSTALLATION ..... 11  
    *CONSTRUCT ENCLOSURE*..... 11  
    *LOWER UNIT INTO ENCLOSURE CUTOUT* ..... 11  
COMMON INSTALLATION .....12  
    *INSTALL CRANK* .....12  
    *INSTALL COOKING GRIDS*.....12  
USING THE GRILL .....13

**USE, CARE, & SERVICE**

OPERATION.....14  
    *CHARCOAL INSTRUCTIONS*.....14  
SERVICING AND CLEANING .....15  
    *CLEANING YOUR GRILL*.....15  
TROUBLESHOOTING.....17  
NOTES PAGE.....18

## INSTALLATION, OPERATION, AND SAFETY INFORMATION

1. The outdoor appliance and surrounding area **MUST** remain clear of flammable substances such as gasoline, yard debris, wood, etc. Maintain a minimum horizontal clearance of 18" (50 cm) (in all directions) from combustible materials/items.
2. Wear gloves and use extreme caution whenever installing and handling this product and its accessories as certain components have sharp edges that can cause personal injury.
3. Adults **MUST** be present when this cooking appliance is operating. This appliance **MUST NOT** be left burning when unattended.
4. Do not store combustible materials in the enclosure directly beneath the appliance.

### **IMPORTANT**

**IN THE EVENT OF A GREASE FIRE, IMMEDIATELY CLOSE THE OVEN LID (IF EQUIPPED), MOVE TO A SAFE DISTANCE, AND ALLOW THE FIRE TO EXTINGUISH ITSELF.**

**WARNING: NEVER cover more than 75% of the cooking or grill surface with griddles, pots, or pans. Overheating will occur and will not perform properly when combustion heat is trapped below the cooking surface.**

# ENCLOSURE REQUIREMENTS

For requirements regarding custom-built enclosures, see below.

To ensure proper operation and safety, the enclosure **MUST** comply with the following:

- Proper construction and cutout openings - see INSTALLATION REQUIREMENTS and ENCLOSURE PARAMETERS sections.
- Proper clearances - see INSTALLATION REQUIREMENTS section.

You **MUST** read and follow these sections for complete enclosure requirement details.

## ENCLOSURE PARAMETERS

### General Guidelines

The enclosure can be constructed according to your individual preference, while following all guidelines found in this manual. **The enclosure MUST (see Fig. 4-1):**

- be installed on a hard and level surface
- be built completely out of non-combustible materials (enclosures and countertop)- using masonry or other types of non-combustible [fireproof] materials.
- have the minimum dimensions specified in Fig. 4-1
- have the correct cutout dimensions (see CUTOUT DIMENSIONS section)
- be designed so that the grill is supported by the stainless-steel hanger extending from the upper portion of the unit (rests on all four sides)- see INSTALLATION section
- have drainage cutouts (if needed) to prevent the accumulation of water within the enclosure
- meet all requirements found in Fig. 4-1 and the following sections

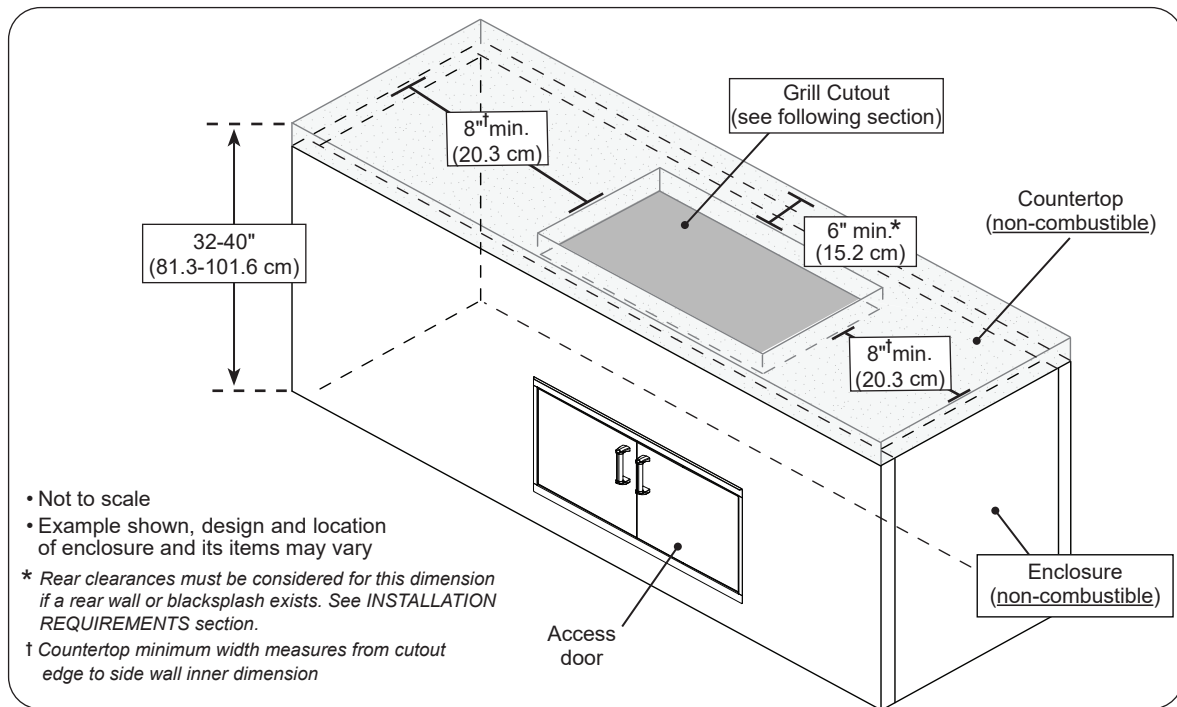

Fig. 4-1 Enclosure specifications

# ENCLOSURE REQUIREMENTS (Cont.)

## Cutout Dimensions

**Important:** These clearance and cutout dimensions below are for non-combustible enclosures.

Description (non-combustible cutouts)	3324 series	3329 series
<b>A</b> Countertop to unit bottom clearance	12"	12"
<b>B</b> Side to side cutout	31 1/4"	24 1/4"
<b>C</b> Front to back cutout	21 1/4"	19 1/4"

**Table 1** - Clearance & Cutout Dimensions (for non-combustible enclosures)

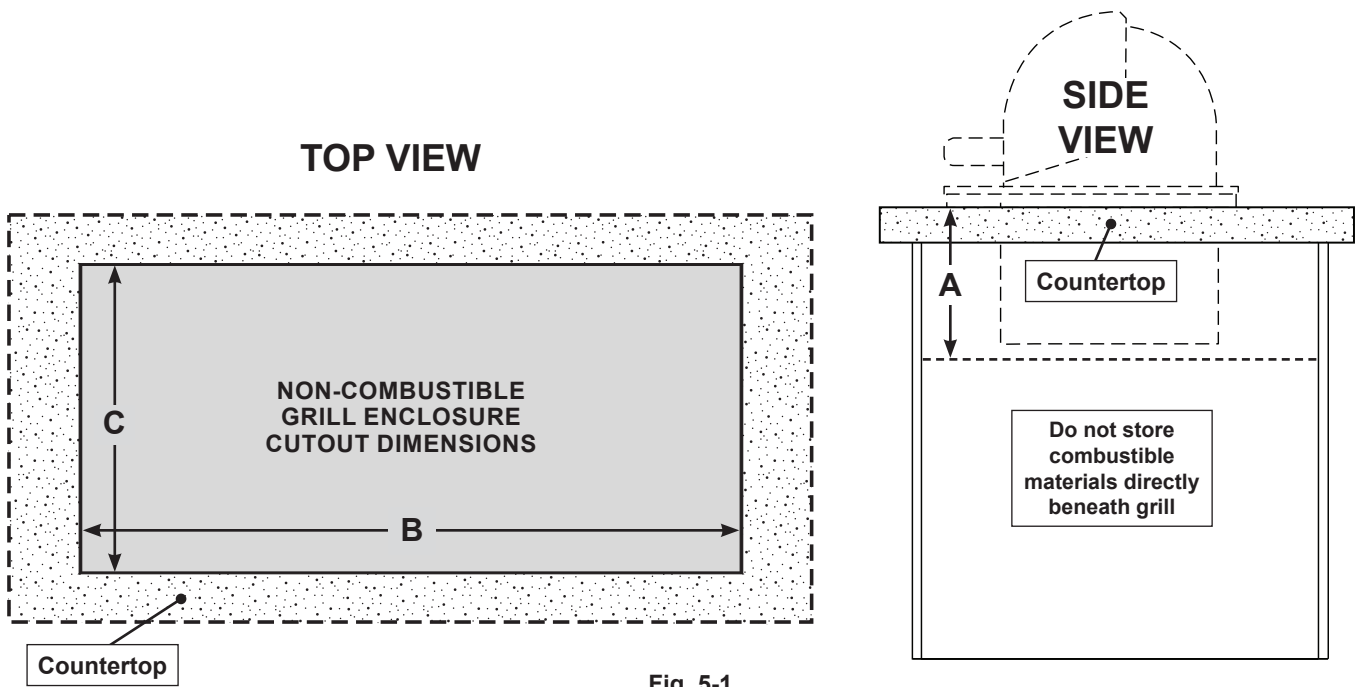

**Fig. 5-1**

## INSTALLATION REQUIREMENTS

Installation must be performed by a qualified professional service technician.

This unit is designed for outdoor use only. **DO NOT** use this unit inside a building, garage, or enclosed area, or under overhead **combustible** construction. **DO NOT** install this unit in or on a recreational vehicle or boat.

**Any constructed outdoor area in which the appliance is used shall comply with one of the following:**

- An outdoor area with walls on three sides, and no overhead cover
- Within a partial outdoor area that includes an overhead cover and no more than two walls. The sidewalls may be parallel, as in a breezeway, or at right angles to each other
- Within a partial outdoor area that includes an overhead cover with walls on three sides, and at least 30% or more of the horizontal periphery of the enclosure that is open and unrestricted

**Note:** All openings must be permanently open.

**Note:** Sliding doors, garage doors, windows, or screened openings are not considered as permanent openings.

Refer to DIAGRAMMATICAL REPRESENTATIONS OF OUTDOOR AREAS section.

### OVERHEAD CONSTRUCTION REQUIREMENTS

**Important:** **DO NOT** use this appliance under combustible overhead construction.

A minimum 5 foot (1.5 meters) clearance is required between the cooking surface and the non-combustible overhead construction. (No combustible materials are allowed within this area.)

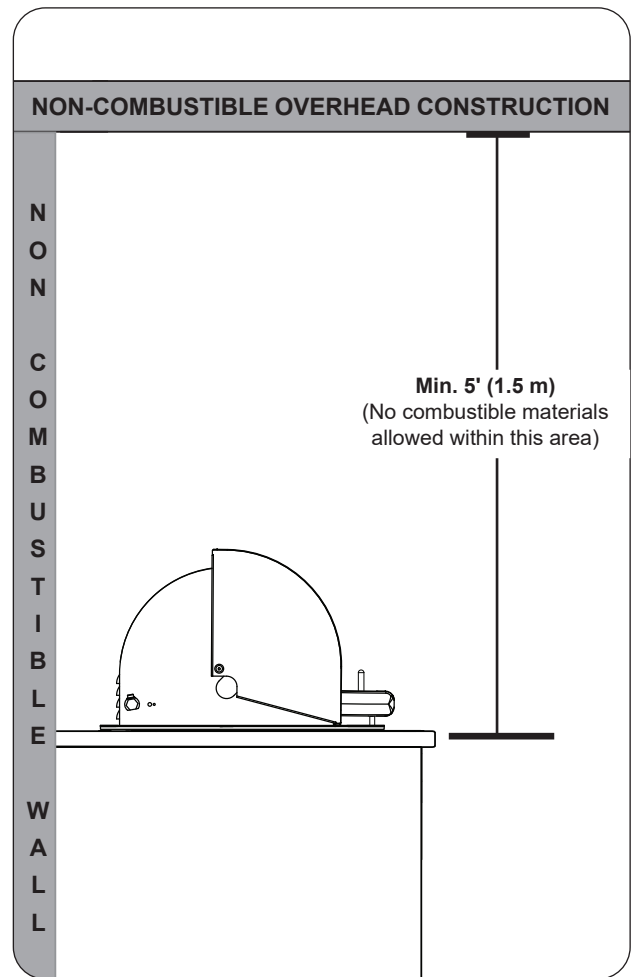

Fig. 6-1 Overhead requirements

## INSTALLATION REQUIREMENTS (Cont.)

**Important:** The grill is not insulated. Refer to the information below to ensure all required clearances are met.

### REAR WALL CLEARANCES

For the minimum clearances between the unit and rear walls, your setup must fall within one (or more) of the following:

#### A. Clearance between unit and strictly non-combustible rear wall

(i.e. brick wall, see Fig. 7-1)

- The unit must have a minimum clearance of 4" (10 cm) from the non-combustible rear wall.

(To allow for proper ventilation and prevent dangerous overheating.)

#### B. Clearance between unit and combustible rear wall

- The unit must have a minimum clearance of 18" (46 cm) from the combustible rear wall (see Fig. 7-2).

### BACKSPLASH CLEARANCE (if applicable)

If a non-combustible backsplash exists, it must have a minimum of a 4" (10 cm) clearance from the rear of the unit (to allow for proper ventilation and prevent dangerous overheating). See Fig. 7-3

**Important:** This 4" (10 cm) backsplash clearance must first be met prior to any non-combustible walls beginning behind it.

### SIDE / CORNER WALL CLEARANCES (if applicable)

The unit must have a minimum clearance of 24" (61 cm) from any side walls (to account for variables in airflow that could affect performance). See Fig. 7-4.

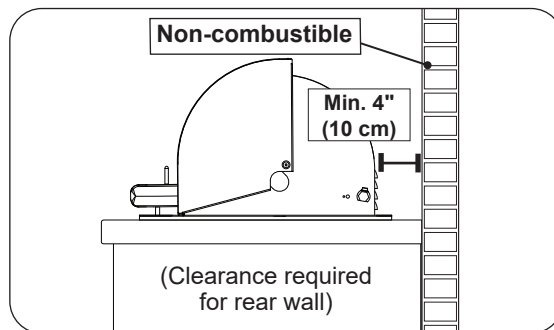

Fig. 7-1 Clearance 'A' Diagram

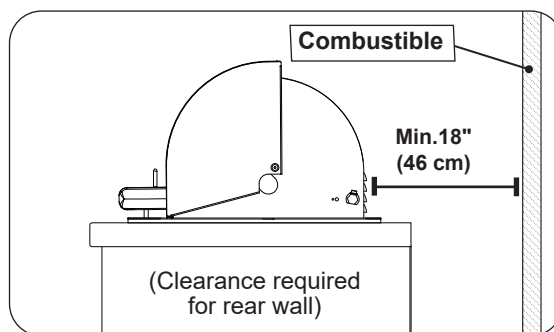

Fig. 7-2 Clearance 'B' Diagram

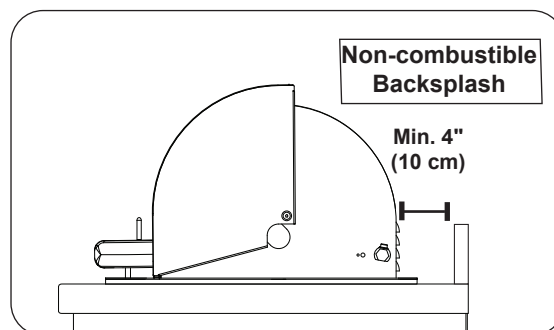

Fig. 7-3 Backsplash clearance

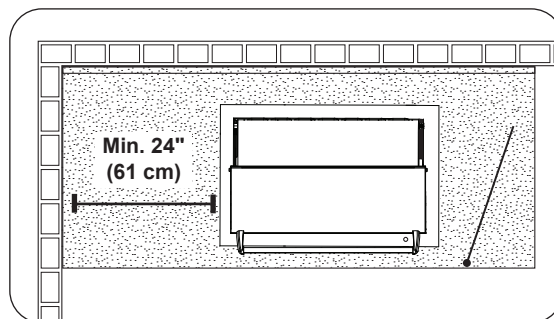
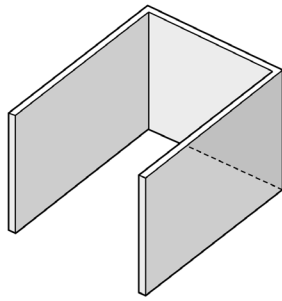

Fig. 7-4 Side/corner wall clearance

# DIAGRAMMATICAL REPRESENTATIONS OF OUTDOOR AREAS

The following figures are diagrammatical representations of outdoor areas. See INSTALLATION REQUIREMENTS section.



**Fig. 8-1** Outdoor area - Example 1

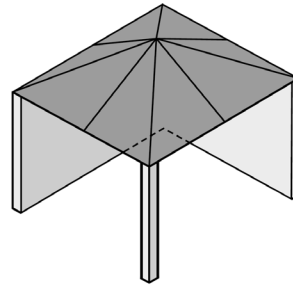
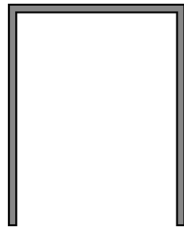

**Fig. 8-2** Outdoor area - Example 2

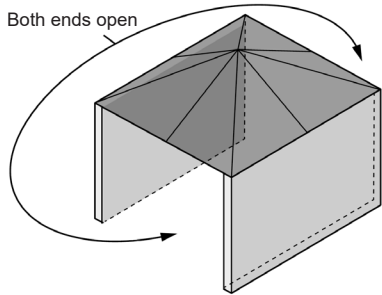
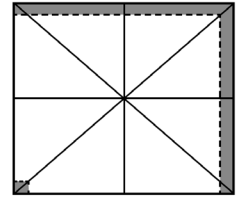

**Fig. 8-3** Outdoor area - Example 3

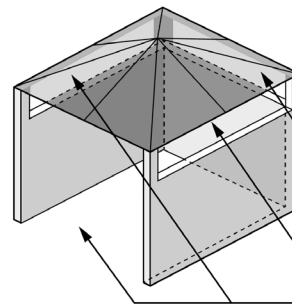
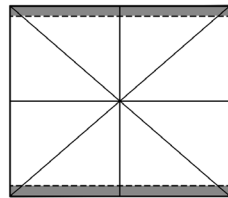

**Fig. 8-4** Outdoor area - Example 4

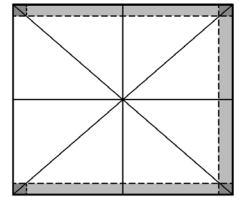

30% or more of the horizontal periphery of the enclosure is open and unrestricted

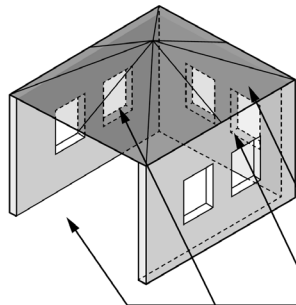

**Fig. 8-5** Outdoor area - Example 5

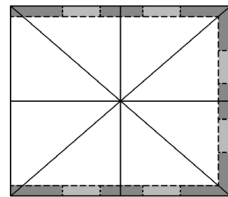

30% or more of the horizontal periphery of the enclosure is open and unrestricted

# MODEL SPECIFICATIONS

Model	Height			Width			Depth	
	(Top to bottom)			(Left to right)			(Front to back)	
	Grill maximum height (A)	Oven hood (if applicable)		Grill maximum width (D)	Grill body frame (E)	Oven hood (if applicable) (F)	Grill maximum depth (G)	Oven hood (if applicable) (H)
Open (B)		Closed (C)						
<b>3324 series</b>	15 3/4" (40 cm)	21 1/2" (54.6 cm)	15 1/2" (39.4 cm)	33 3/4" (85.7 cm)	31 1/4" (79.4 cm)	29" (73.7 cm)	23" (58.4 cm)	23 1/2" (59.7 cm)
<b>3329 series</b>	15" (38.1 cm)	21 1/2" (54.6 cm)	15 1/2" (39.4 cm)	26 1/4" (66.7 cm)	24 1/4" (61.6 cm)	24 3/4" (62.9 cm)	23" (58.4 cm)	23 1/2" (59.7 cm)

**Table 2 - Grill Dimensions**

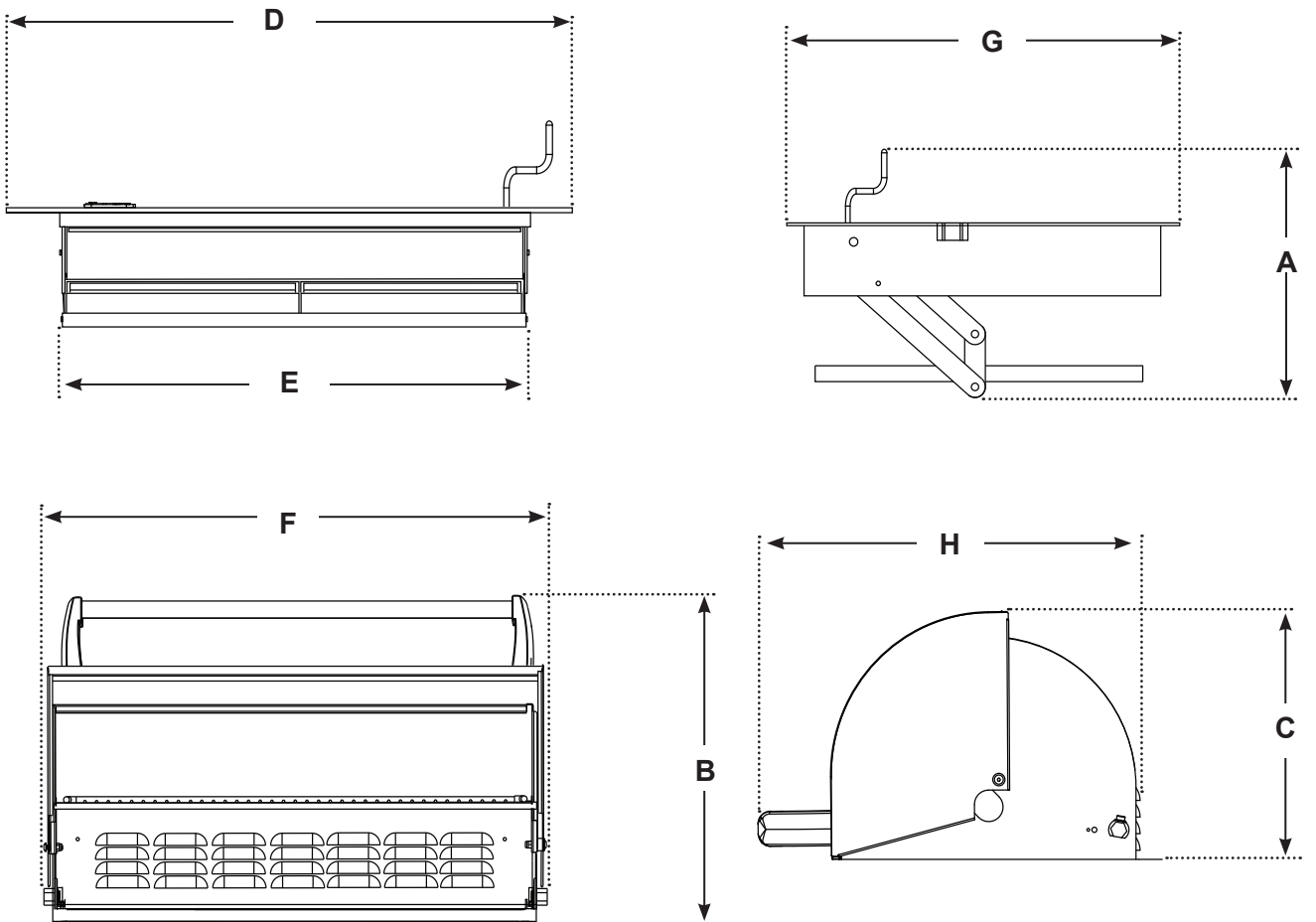
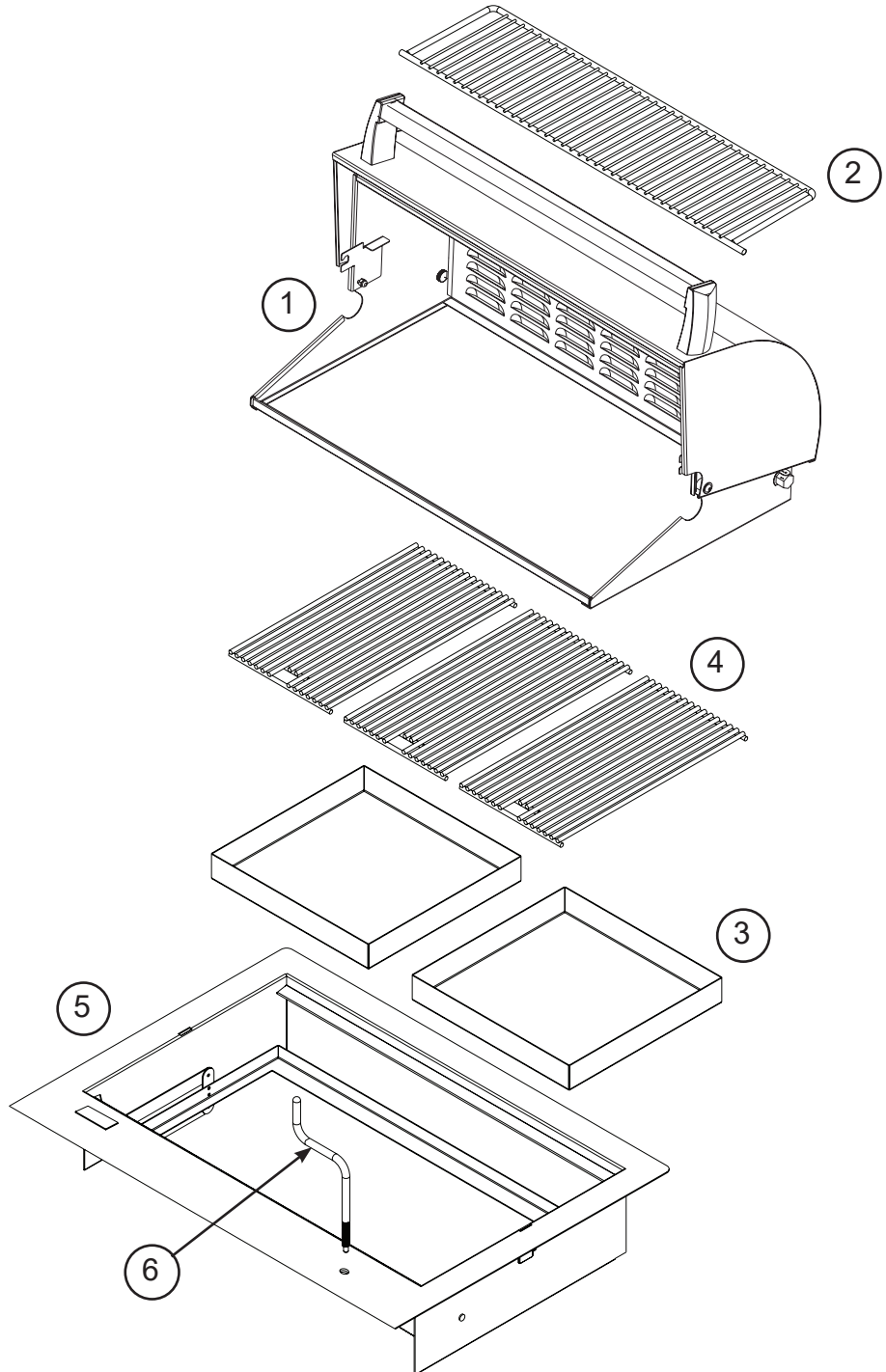

**Fig. 9-1**

# REPLACEMENT PARTS LIST

Item	Description	3324		3329	
		Part No.	Qty.	Part No.	Qty.
1.	Stainless steel grill oven (optional)	23733	1	3731	1
2.	Warming rack (optional)	3673S	1	3671S	1
3.	Charcoal pan	3304	2	3302	1
4.	Stainless steel cooking grids (set of 2 or 3) (optional)	3543-DS-3	1	3537-S-2	1
5.	Grill assembly	3320-55	1	3325-55	1
6.	Crank	3301	1	3301	1

Replacement parts can be ordered from your local Fire Magic® dealer.



3324 model shown

**IMPORTANT**  
Remove all packing material and discard prior to use.

## CONSTRUCT ENCLOSURE

A custom-built enclosure will need to be constructed. Construct the enclosure according to your individual install preference, while following the guidelines found in the ENCLOSURE REQUIREMENTS and INSTALLATION REQUIREMENTS sections.

- Construct the enclosure in an appropriate location (ensure all requirements of this manual and all local codes are met when determining location).
- **Follow all information regarding enclosure parameters, cutout dimensions, and clearances listed in the ENCLOSURE REQUIREMENTS and INSTALLATION REQUIREMENTS sections.** Failure to do so will prevent proper operation and can cause property damage or personal injury.

## LOWER UNIT INTO ENCLOSURE CUTOUT

Carefully place the unit into the cutout in the enclosure, making sure not to damage any part of the unit (see Fig. 11-2).

- Ensure the unit is correctly inserted without any obstructions between it and the countertop.
- Ensure the unit is placed so that it sits flush against the enclosure front wall. See the COUNTERTOP OVERHANG section in ENCLOSURE REQUIREMENTS for details.
- If installing on a countertop with an irregular/textured surface, a bead of silicone sealer rated for 500° F (260° C) or higher is recommended to protect from the elements.

## GRILL OVEN (optional)

Align the grill oven (Fig. 11-2 and Fig. 11-3) over the grill and rest it in place. Reference the PARTS LIST for orientation.

**Note:** The crank handle must be positioned with the arm pointing from left to right in order for the oven hood to close correctly.

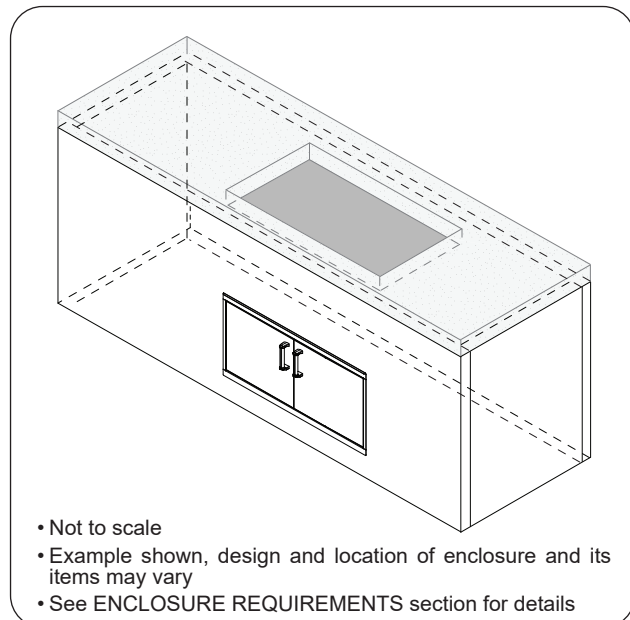

**Fig. 11-1** Enclosure construction overview (if applicable)

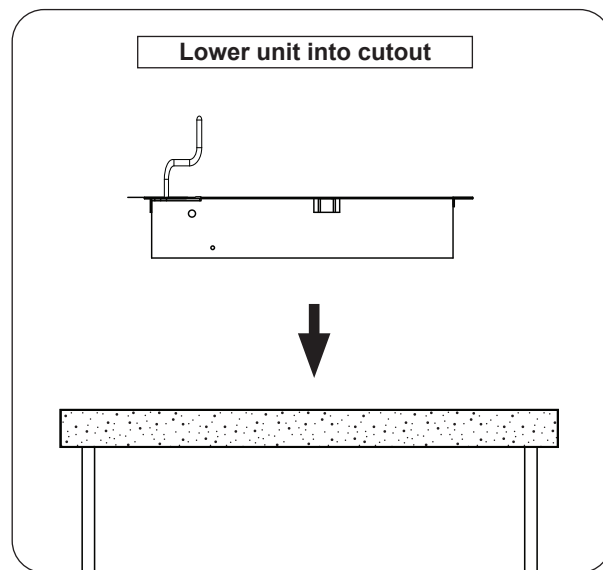

**Fig. 11-2** Lower in unit into cutout



**Fig. 11-3** Grill oven (if applicable)

## INSTALLATION

### INSTALL CRANK

Fit the crank handle into the hole on the top right side of the face. Aligning it carefully, screw it into the nut on the frame. After installation, crank the handle in and out to raise and lower the charcoal pan. See Fig. 12-1.

### INSTALL CHARCOAL PAN

Carefully orient the charcoal pan(s) inside the grill, and rest on the pan frame. See Fig. 12-2.

### INSTALL WARMING RACK (If applicable)

Taking the warming rack, grip along the bottom edge and hold the rack vertical so the rounded shoulders are topmost and the rod bottommost. See Fig. 12-3, A:

- Carefully lift the warming rack up under the outer oven edges and place the rod ends into the hanging brackets. See Fig. 12-3, B.
- Allow the rack to rotate away from you so that the sides rest on the support lip (Fig. 12-3, C). As the shelf rotates into position it will lock into the holding bracket. Check it is secure in position before use.

### INSTALL COOKING GRIDS (if applicable)

Carefully place each cooking grid onto the front and rear grid rests of the grill. See Fig. 12-4.

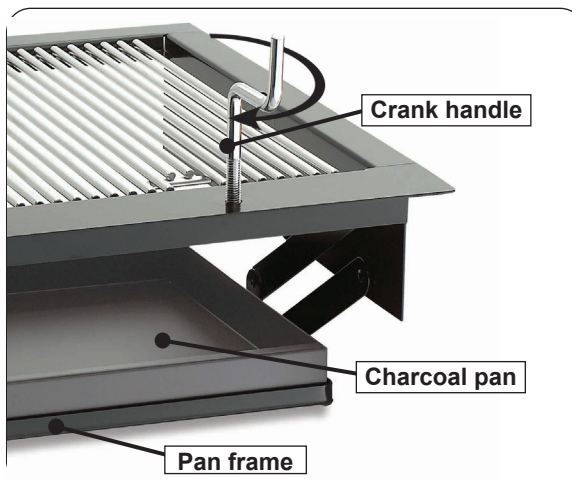

Fig. 12-1 Installation



Fig. 12-2 Install charcoal pan(s)

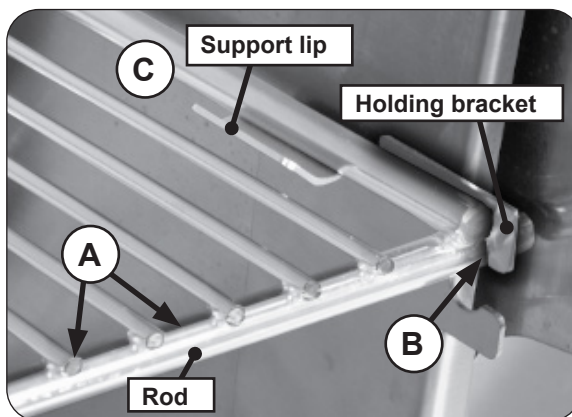

Fig. 12-3 Install warming rack

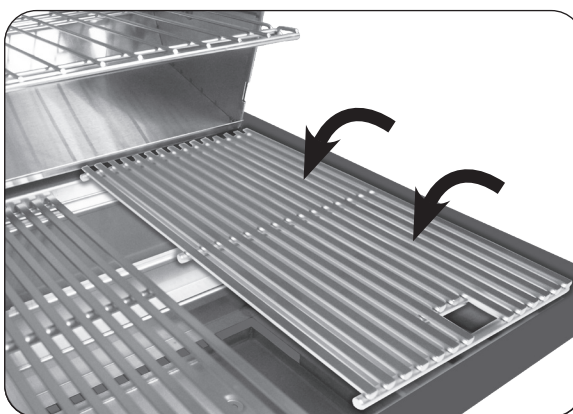

Fig. 12-4 Install cooking grids

### BEFORE INITIAL USE

Ensure that:

- the grill has been properly installed by a qualified professional service technician as instructed in this manual.
- you have read and understand all of the information in this manual.

### BEFORE EACH USE

Ensure that:

- the surrounding area of the unit is clear and free at all times.
- the cooking area and drip tray are clean, and the drip tray is properly installed.

### OPERATION

- **The grill becomes HOT during use, INCLUDING THE CHARCOAL ACCESS DOOR HANDLE AND CRANK. NEVER touch any part of the cooking area or surrounding hot surfaces with bare hands. Use long-handled insulated BBQ tools and wear an insulated glove / oven mitt.**
- **Always keep your face and body as far from the grill as possible during use. Avoid wearing loose-fitting clothing as they could ignite.**
- **This appliance is designed as an attended appliance. DO NOT leave this appliance burning when unattended.**
- **NEVER cover more than 75% of the cooking or grill surface with griddles or pans to prevent overheating.**

After reading and understanding all bullets above, follow these steps to light and use your grill:

1. Load, light, and adjust the charcoal per the OPERATION section.
2. Allow the grill to preheat until the desired cooking temperature is reached.
3. Place the food on the grill and cook as desired. Monitor the charcoal and adjust the grilling heat if necessary (see the CHARCOAL PAN section on the following page).
4. See the section below and the following pages for all other information regarding use.

### AFTER EACH USE

1. Brush the cooking grids to remove all residue.

**CAUTION:** Use long-handled insulated BBQ tools and wear an insulated glove / oven mitt.

2. It is recommended to operate with high heat and hood closed for 10-15 minutes to burn off all grease.
3. Cover the grill once it has completely cooled.

**Note:** For additional cleaning, refer to the SERVICING AND CLEANING section.

## OPERATION

Simple to use, this elegant stainless-steel charcoal grill has the added benefit of an adjustable charcoal pan to allow you to change the height of the charcoal while cooking.

### CHARCOAL INSTRUCTIONS

1. Remove the cooking grids and pile your charcoal on the charcoal pan(s). Avoid spillage.

**WARNING:** When adding charcoal, spread it across the charcoal pan evenly and DO NOT exceed a height of 1" (2.5 cm) above the charcoal pan. Excessive amounts of charcoal may cause over heating and damage to your grill.

2. Follow the instructions supplied with your charcoal/fuel for lighting.

**WARNING:** All surfaces of charcoal unit will become **HOT** during use. Exercise caution when adding charcoal or cranking the charcoal pan up/down. Use long-handled insulated BBQ tools and wear an insulated glove / oven mitt.

3. Turn the crank handle to raise or lower the charcoal pan to increase or decrease the grill heat as needed.

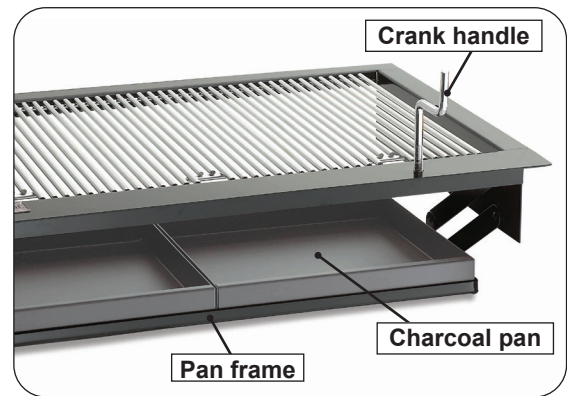

Fig. 14-1 Operation

## SERVICING AND CLEANING

**Your grill requires regular cleaning and maintenance.** Refer to these instructions for details. Performing these procedures will ensure proper operation, appearance, and safety.

### WARNINGS

- Prior to servicing or cleaning make sure the unit is completely cool.
- Wear appropriate gloves and safety glasses during any servicing or cleaning.
- DO NOT spray any cleaner or liquids on the grill when hot.
- The grill MUST be cleaned regularly to prevent grease build-up and other food deposits. A clean and well maintained grill prevents the risk of grease build-up and grease fires.
- Verify proper operation after servicing or deep cleaning.
- See INSTALLATION, OPERATION, AND SAFETY INFORMATION section for additional related information.

### CLEANING YOUR GRILL

#### Before Each Use

1. **Inspect and clean the exterior surfaces of the unit:** With a cool grill, clean any dust, grease, splatter, or spills as needed with a damp clean cloth.

#### After Each Use

1. **Perform a burn-off and clean the cooking grids:** Operate the grill hot with the hood closed for 15 minutes to burn-off food and grease and allow for an easier cooking grid clean. Then extinguish the hot charcoal and use a grill or scraper brush to clean the cooking grids of all residue. Use long-handled insulated BBQ tools and wear an insulated glove / oven mitt.
2. **Clean the charcoal pan:** After each use, when the grill is cool, empty the charcoal pans of all ash and drippings. Dispose of all ashes appropriately into a fireproof container.  
  
Clean the charcoal pan with a soapy water solution if needed. Rinse and dry completely. Replace the charcoal pan back to the grill.
3. **Cover your grill:** Once the grill is dry and cool, cover your grill with a Fire Magic protective cover (not included).

#### Optional Stainless Steel Grill Oven Hood

With a cool grill, use a grill cleaner (or a soapy water solution) and a clean cloth to remove grease and dirt from the inside and outside of the grill. For tough deposits, a copper pad can be used. Always wipe with the grain. See Fig. 15-1. Rinse and dry completely. For the exterior, follow up with a stainless steel cleaner and a clean cloth.

If this routine cleaning is not performed, the stainless steel may become dull and develop surface rust (due to use and atmospheric conditions). If left uncleaned, significant damage and pitting may occur.

**Important:** DO NOT use steel wool, any other metal tools, or any other cleaners/chemicals to clean the exterior other than recommended above. Such items promote rust.

**Note:** Due to the nature of stainless steel, temperatures produced by the grilling process will cause discoloration. This can be reduced by routine cleaning.



**Fig. 15-1** Grill oven (if applicable)

## SERVICING AND CLEANING (cont.)

### For Environments High In Salt, Chloride, Or Other Corrosive Chemicals

When this grill is installed in a corrosive environment such as near the ocean (salt air), poolside (chlorine and/or pool chemicals) or any other location with exposure to high salt/chloride content or corrosive chemicals/solutions, it will be more susceptible to corrosion and **MUST** be maintained/cleaned **more frequently**.

- **DO NOT** store any corrosive chemicals (chlorine, hydrochloric acid, fertilizer, etc.) near your stainless steel grill.
- **DO NOT** allow any corrosive materials (masonry dust, debris, etc.) to settle on your stainless steel grill.
- These environments, chemicals, and materials may cause the 304 stainless steel to develop surface rust and consequently pitting. Under these conditions the grill exterior **MUST** be cleaned at least monthly. Inspect your grill often and clean accordingly.

### Protecting Your Grill

An optional protective cover will protect your grill when not in use. Install the cover on a cool and dry grill. **DO NOT** cover a damp grill. During high humidity or after rainy conditions, remove the cover to dry trapped moisture if present. (If the cover is installed over a damp grill it can cause surface rust.)

Ensure that the **INSIDE** of the cover is DRY before putting it back on the grill.

## TROUBLESHOOTING

If you have trouble with the unit, please use this list to identify the problem. By trying one or more of the solutions to the possible cause, you should be able to solve the problem. If this list does not cover your present problem, or if you have other technical difficulties with the unit, please contact your local dealer.

PROBLEM	POSSIBLE CAUSE	CORRECTION
<b>Charcoal grill is not getting hot</b>	1. Dirty grill	1. Remove ashes from previous grilling. Ashes can trap moisture, causing difficulty to light charcoal.
	2. Damp charcoal	2. Ensure your charcoal is dry when lighting.
	3. Low quality charcoal	3. Use quality brand charcoal. Low quality brands can struggle reaching temperature and remaining lit.
	4. Old or used charcoal	4. Use new charcoal. Old or used charcoal can result in the grill not reaching temperature and can burn out quicker giving inconsistent heat.
	5. Charcoal went out	5. Carefully re-light your charcoal by following the instructions supplied with your charcoal. Ensure your charcoal is properly lit before spreading to distribute heat.
	6. Charcoal pan height is too low	6. Adjust the crank to raise the charcoal pan closer to the cooking grids.

NOTES PAGE

Please use this page to record any information that you may want to have at hand.