Installation, Operation and Maintenance Instructions

Outdoor Refrigerators

3589-DR

3589-DL



CONTENTS

Contents:

Safety information	2
Unpacking your appliance	3
Installing your appliance	4
Cabinet clearances	4
Leveling the appliance	4
Electrical connection	5
Installing the anti-tip device	6
Product Dimensions	8
Using your Electronic control	9
Starting your appliance	9
Turning your appliance "ON" or "OFF"	9
Adjusting the temperature	9
Refrigerator operation	9
Alarms	9
Door ajar	9
Temperature sensor fault	9
High and low temperature alarm	9
Shelving configurations	10
Care and cleaning	11
Long term storage / winterization	12
Stainless steel maintenance	13
Energy saving tips	13
Troubleshooting	14
Warranty	15

Important Safety Instructions

Warnings and safety instructions appearing in this guide are not meant to cover all possible conditions and situations that may occur. Common sense, caution, and care must be exercised when installing, maintaining, or operating this appliance.

Recognize Safety Symbols, Words, and Labels.

WARNING

WARNING-You can be killed or seriously injured if you do not follow these instructions.

CAUTION

CAUTION-Hazards or unsafe practices which could result in personal injury or property / product damage.

NOTE

NOTE-Important information to help assure a problem free installation and operation.



Certified to:
Household Refrigerators and Freezers
CSA C22.2 No.63

Refrigeration Equipment
CAN/CSA C22.2 No.120

Safety of Household and Similar Appliances
CAN/CSA C22.2 No.60335-1

Safety of Household and Similar Electrical Appliances
CAN/CSA C22.2 No.60335-2-24

WARNING

State of California Proposition 65 Warning:
This product contains one or more chemicals known to the State of California to cause cancer.

WARNING

State of California Proposition 65 Warning:
This product contains one or more chemicals known to the State of California to cause birth defects or other reproductive harm..

UNPACKING YOUR APPLIANCE



WARNING

EXCESSIVE WEIGHT HAZARD

Use two or more people to move product.
Failure to do so can result in personal injury.

Remove Interior Packaging

Your appliance has been packed for shipment with all parts that could be damaged by movement securely fastened. Remove internal packing materials and any tape holding internal components in place. The owners manual is shipped inside the product in a plastic bag along with the warranty registration card, and other accessory items.

Important

Keep your carton and packaging until your appliance has been thoroughly inspected and found to be in good condition. If there is damage, the packaging will be needed as proof of damage in transit. Afterwards please dispose of all items responsibly.



WARNING

WARNING - Dispose of the plastic bags which can be a suffocation hazard.

Note to Customer

This merchandise was carefully packed and thoroughly inspected before leaving our plant. Responsibility for its safe delivery was assumed by the retailer upon acceptance of the shipment. Claims for loss or damage sustained in transit must be made to the retailer.

NOTE

DO NOT RETURN DAMAGED MERCHANDISE TO THE MANUFACTURER - FILE THE CLAIM WITH THE RETAILER.



CAUTION

If the appliance was shipped, handled, or stored in other than an upright position for any period of time, allow the appliance to sit upright for a period of at least 24 hours before plugging in. This will assure oil returns to the compressor. Plugging the appliance in immediately may cause damage to internal parts.

FIREMAGIC		 C US Energy Verified MC233973 REFRIGERATOR OUTDOOR RATED			
CITY OF INDUSTRY, CA 91746					
MODEL NO.	<input type="text"/>				
SERVICE NO.	<input type="text" value="XXXXXXXXXXXX"/>				
SERIAL NO.	<input type="text" value="XXXXXXXXXXXX"/>				
HZ <input type="text"/>	VOLTS <input type="text"/>	AMPS <input type="text"/>	R134A	<input type="text"/>	OZ
TEST PRESSURE 140 PSI LOW SIDE 300 PSI HIGH SIDE					

Figure 1



WARNING

WARNING - Help Prevent Tragedies

Child entrapment and suffocation are not problems of the past. Junked or abandoned refrigerators are still dangerous - even if they sit out for "just a few hours".

If you are getting rid of your old refrigerator, please follow the instructions below to help prevent accidents.

Before you throw away your old refrigerator or freezer:

- Take off the doors or remove the drawers.
- Leave the shelves in place so children may not easily climb inside.

INSTALLING YOUR APPLIANCE

Select Location

The proper location will ensure peak performance of your appliance. We recommend a location where the unit will be out of direct sunlight and away from heat sources. To ensure your product performs to specifications, the recommended installation location temperature range is from 55 to 115°F (13 to 46°C).

Cabinet Clearance

Ventilation is required from the bottom front of the appliance. Keep this area open and clear of any obstructions. Adjacent cabinets and counter top can be installed around the appliance as long as the front grille remains unobstructed.

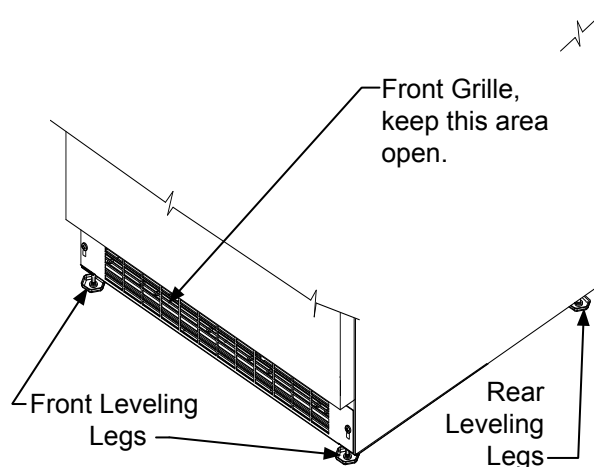

Figure 2

Leveling Legs

Adjustable legs at the front and rear corners of the appliance should be set so the unit is firmly positioned on the floor and level from side to side and front to back. The overall height of your Firemagic appliance may be adjusted between the minimum, 33³/₄" (85.7 cm), by turning the leveling leg in (CW ↻) and the maximum, 34³/₄" (88.3 cm) by turning the leveling leg out (CCW ↻).

To adjust the leveling legs, place the appliance on a solid surface and protect the floor beneath the legs to avoid scratching the floor. With the assistance of another person, lean the appliance back to access the front leveling legs. Raise or lower the legs to the required dimension by turning the legs. Repeat this process for the rear by tilting the appliance forward using caution. On a level surface check the appliance for levelness and adjust accordingly.

The front grille screws may be loosened and the grille adjusted to the desired height. When adjustment is complete tighten the two front grille screws. (See Figure 5).



CAUTION

Front Grille

Do not obstruct the front grille. The openings within the front grille allow air to flow through the condenser heat exchanger. Restrictions to this air flow will result in increased energy usage and loss of cooling capacity. For this reason it is important this area not be obstructed and the grille openings kept clean. Firemagic does not recommend the use of a custom made grille as air flow may be restricted. (See Figure 2).

INSTALLING YOUR APPLIANCE

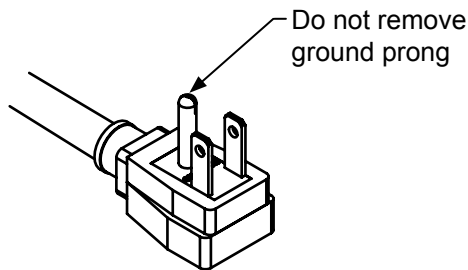

Figure 3

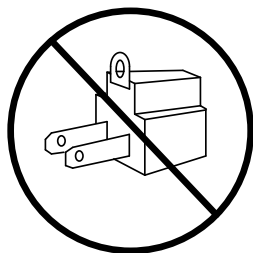

Figure 4

WARNING

Electrical Shock Hazard

- Do not use an extension cord with this appliance. They can be hazardous and can degrade product performance.
- This appliance should not, under any circumstances, be installed to an un-grounded electrical supply.
- Do not remove the grounding prong from the power cord. (See Figure 3).
- Do not use an adapter. (See Figure 4).
- Do not splash or spray water from a hose on the appliance. Doing so may cause an electrical shock, which may result in severe injury or death.

Electrical Connection

A grounded 115 volt, 15 amp dedicated circuit is required.

This product is factory equipped with a power supply cord that has a three-pronged, grounded plug. It must be plugged into a mating grounding type receptacle in accordance with the National Electrical Code and applicable local codes and ordinances (see Figure 6). If the circuit does not have a grounding type receptacle, it is the responsibility and obligation of the customer to provide the proper power supply. The third ground prong should not, under any circumstances, be cut or removed.

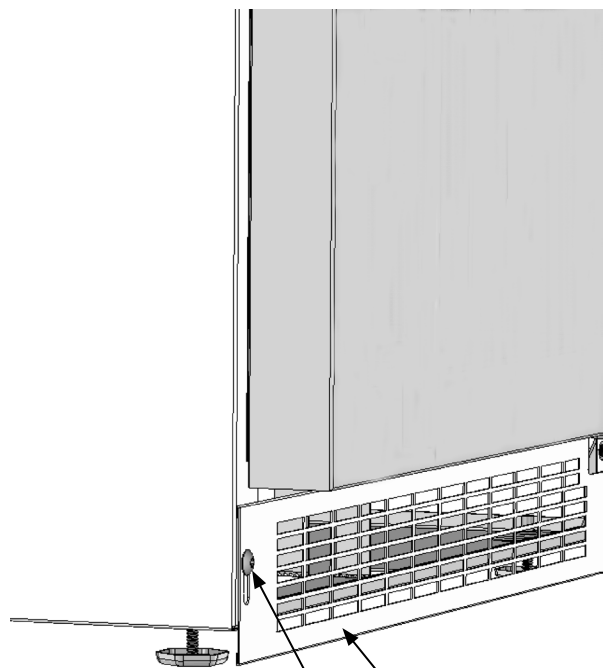

Figure 5

Front grille

Front grille screw

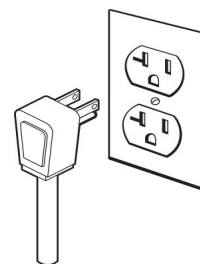

Figure 6

NOTE

Ground Fault Circuit Interrupters (GFCI) are prone to nuisance tripping which will cause the appliance to shut down. GFCI's are generally not used on circuits with power equipment that must run unattended for long periods of time, unless required to meet local building codes and ordinances.

INSTALLING THE ANTI TIP DEVICE FOR FREESTANDING INSTALLATIONS

WARNING

- ALL APPLIANCES CAN TIP RESULTING IN INJURY.
- INSTALL THE ANTI-TIP BRACKET PACKED WITH THE APPLIANCE.
- FOLLOW THE INSTRUCTIONS BELOW

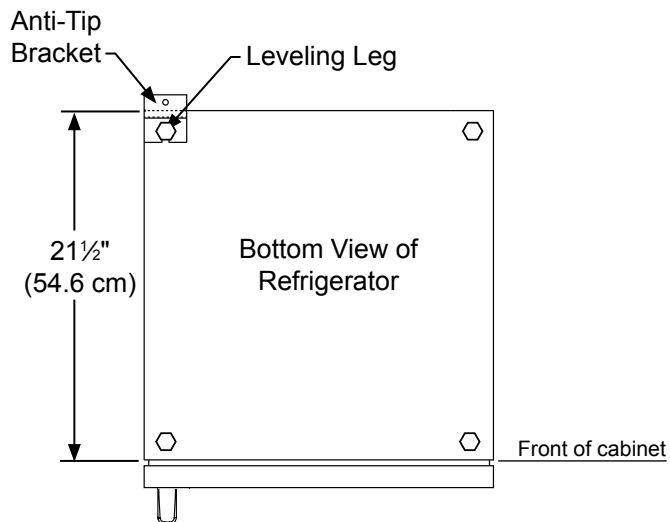

Anti-Tip Device

WARNING

If your refrigerator is not located under a counter top (free standing), you must use an anti-tip device installed as per these instructions. If the refrigerator is removed from its location for any reason, make sure that the device is properly engaged with the anti-tip bracket when you push the refrigerator back into the original location. If the device is not properly engaged, there is a risk of the refrigerator tipping over, with the potential for property damage or personal injury.

Step by step instructions for locating the position of the bracket:

1) Decide where you want to place the refrigerator. Slide it into place, being careful not to damage the floor, leaving 1" (2.5 cm) of clearance from the rear wall to allow room for the anti-tip bracket.

2) Raise the rear leveling legs approximately 1/4" (6 mm) to allow engagement with the anti-tip bracket. Level the unit by adjusting all the leveling legs as required. Turning the leveling leg counterclockwise will raise the unit and clockwise will lower the unit.

3) Make sure the refrigerator is in the desired location, then mark on the floor the rear and side corner of the cabinet where the anti-tip bracket will be installed. If the installation does not allow marking the rear corner of the cabinet, then make temporary lines on the floor marking the front corner of the cabinet, excluding the door. Slide the refrigerator out of the way. From the temporary line extend the sidewall line back 21 1/2" (54.6 cm) as shown in Figure 8.

4) Align the anti-tip bracket to the marks on the floor so the side of the bracket lines up with the side of the cabinet mark, and the "V" notches on the anti-tip bracket line up with the end of the 21 1/2" (54.6 cm) line (Rear of cabinet line).

5) Fasten the anti-tip bracket to the floor using the supplied screw. (See Figure 8).

6) Slide the cabinet back into position, making sure the rear cabinet leveling leg slides under the anti-tip bracket engaging the slot.

NOTE

If installing on a concrete floor, concrete fasteners are required, (not included with the anti-tip kit).

CAUTION

Any finished flooring should be protected with appropriate material to avoid damage when moving the unit.

Floor Mount Installation

The anti-tip bracket is to be located on the floor in the left or right rear corner of the refrigerator as shown in Figure 7.

INSTALLING THE ANTI TIP DEVICE FOR FREESTANDING INSTALLATIONS

NOTE

When the floor mounted anti-tip bracket is used the minimum adjusted height of the cabinet is increased by $\frac{3}{8}$ " (9 mm).

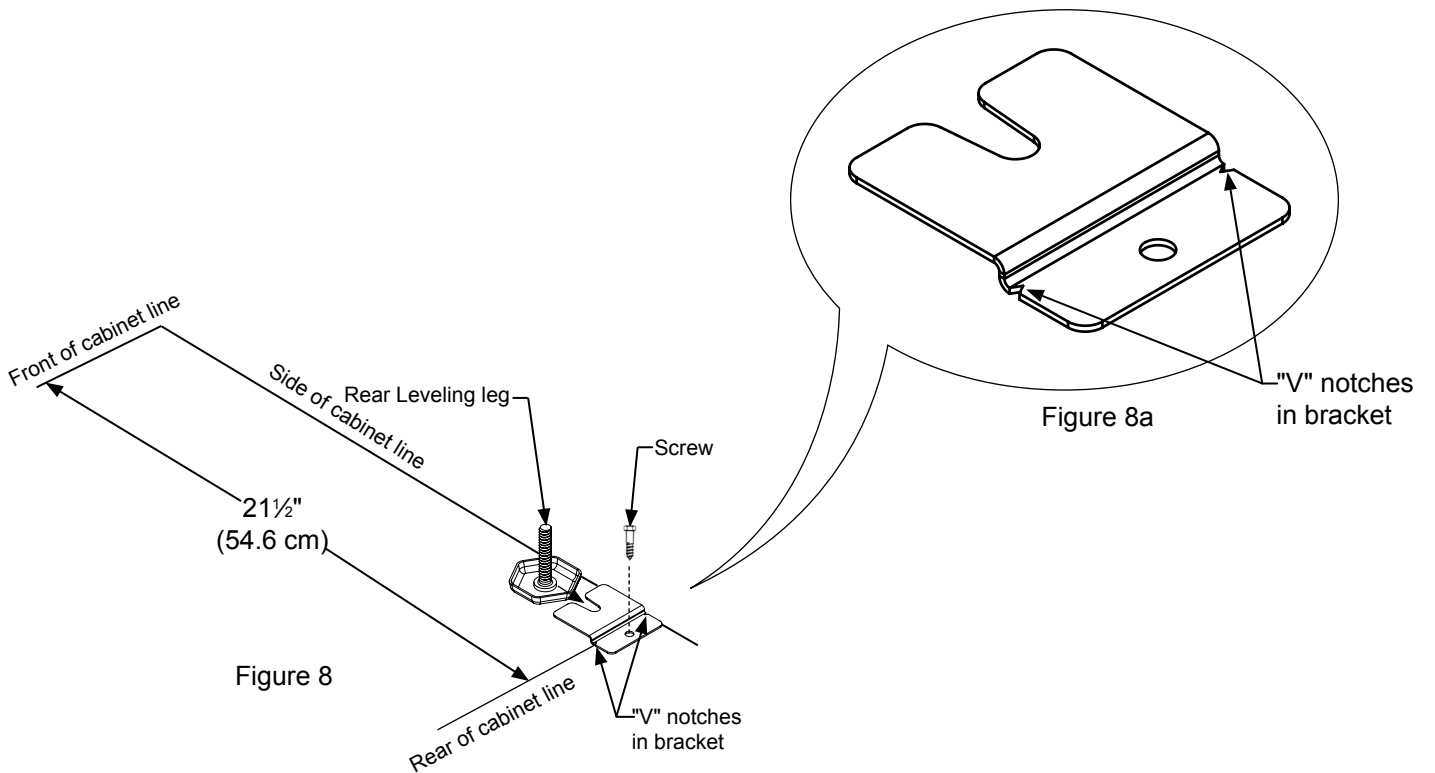

PRODUCT DIMENSIONS

MODEL	ROUGH-IN OPENING DIMENSIONS			CABINET DIMENSIONS					
	"A"	"B"	"C"	"D"	"E"	"F"	"G"	"H"	"J"
3589-DR 3589-DL	24.5" (62 cm)	**34" to 35" (86.4 to 88.9 cm)	*	23 ⁷ / ₈ " (60.7 cm)	33 ³ / ₄ " to 34 ³ / ₄ " (85.7 to 88.3 cm)	23 ²³ / ₃₂ " (60.2 cm)	26 ¹ / ₃₂ " (66.9 cm)	46 ¹³ / ₃₂ " (117.9 cm)	26 ⁹ / ₁₆ " (67.5 cm)

PRODUCT DATA		
MODEL	ELECTRICAL REQUIREMENTS #	PRODUCT WEIGHT
3589-DR 3589-DL	115V/60Hz/15A	140 lbs (63.6 kg)

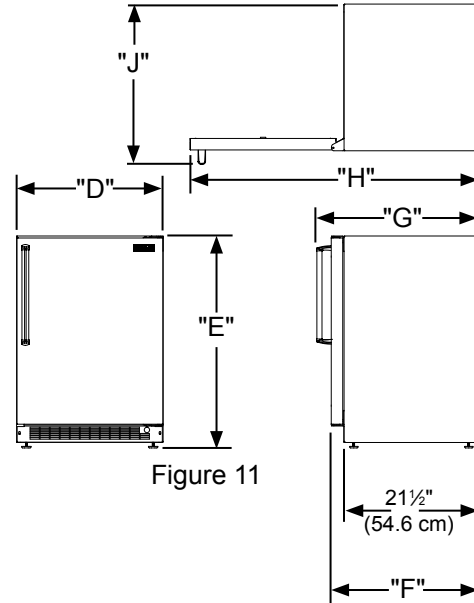
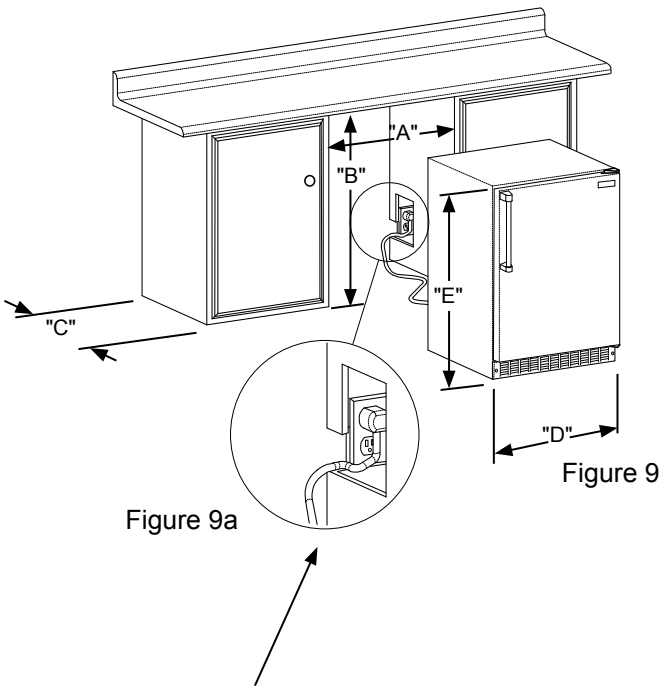

If necessary to gain clearance inside the rough-in opening a hole can be cut through the adjacent cabinet and the power cord routed through this hole to a power outlet. Another way to increase the available opening depth is to recess the power outlet into the rear wall to gain the thickness of the power cord plug. Not all recessed outlet boxes will work for this application as they are too narrow, but a recessed outlet box equivalent to Arlington #DVFR1W is recommended for this application, (see Figure 10).

* Depth dimension of rough-in opening may vary depending on each individual installation. To recess entire door "F" dimension plus 1" (2.5 cm) for thickness of power cord plug is required.

** Minimum rough-in opening required is to be larger than the adjusted height of the cabinet.

A grounded 15 amp dedicated circuit is required. Follow all local building codes when installing electrical and appliance.

WARNING

Floor mount Anti-tip Bracket must be installed for freestanding applications. Not required for built in applications.

USING YOUR ELECTRONIC CONTROL

Figure 12
close-up of
control

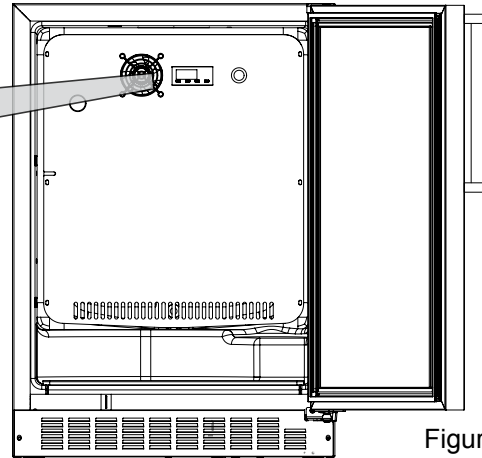
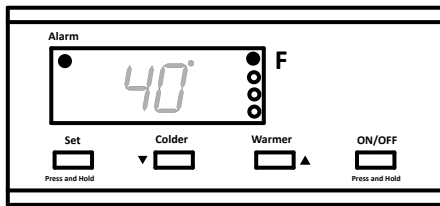

Figure 13

Starting your refrigerator

Plug the refrigerator power cord into a wall outlet. Your refrigerator will begin cooling after power is applied. If your refrigerator does not start, check that the refrigerator is turned on and the set temperature is cold enough.

Turning your refrigerator ON or OFF

If the refrigerator is on, the refrigerator temperature will be shown on the display. To turn the refrigerator off, press and hold the "ON/OFF" button for three (3) seconds. "OFF" will appear on the display.

If the refrigerator is not on, "OFF" will be shown on the display. To turn the refrigerator on, press and hold the "ON/OFF" button for three (3) seconds. The refrigerator temperature will be shown on the display.

Set temperature

To set the refrigerator temperature, press and hold the "SET" button. When the "SET" button is pressed, the display will show the set temperature. While holding the "SET" button, press the "WARMER" or "COLDER" buttons to adjust set temperature.

Refrigerator operation

The available temperature range of the refrigerator is 34° to 42°F (1° to 6° C).

It may take up to 24 hours for your refrigerator to reach desired temperature. This will depend on amount of content loaded and number of door opening and closings.

For best results allow refrigerator to "pull down" to desired set temperature before loading. Once contents are loaded, allow at least 48 hours for temperature to stabilize before making any adjustments to the set temperature.

Alarms

Your electronic control will monitor refrigerator function and alert you with a series of audible and visual alarms.



- **Door Ajar Alarm:** If the door has been left open for over five (5) minutes, the alarm will sound in one (1) second intervals. The display panel will flash "do" and the Alarm LED located at the top left of the display below the word "Alarm" will be illuminated. This will stop as soon as the door is closed.



- **Temperature Sensor Fault:** If the controller detects that the temperature sensor is not properly functioning, a temperature sensor alarm will sound in one (1) second intervals. "E1" will flash on the display panel and the Alarm LED located at the top left of the display below the word "Alarm" will be illuminated. Please call Firemagic Customer Service or your dealer if this error code is displayed.



- **High and Low Temperature Alarm:** If the storage compartment temperature deviates excessively from the set-point temperature, the alarm will sound in (1) second intervals. The display panel will flash either "Hi" or "Lo" depending upon the condition and the Alarm LED light at the top left of the display below the word "Alarm" will be illuminated. The alarm will remain active until the condition is corrected.

NOTE

After a high temperature alarm condition, check all perishables to ensure they are safe for consumption.

NOTE

The temperature alarm may occur as a result of high usage or introduction of warm contents to the storage compartment. If the temperature alarm continues to occur, your unit may require service.

Alarm Mute

Press any key to mute the audible portion of an alarm.

NOTE

This action will only mute the alarm. If the condition that caused the alarm continues, the alarm code will continue to flash and will sound for 20 seconds every 60 minutes.

SHELVING CONFIGURATIONS

Loading Tips and Suggestions

Your appliance is equipped with a cantilever shelf system which provides maximum adjust ability and customizing of the shelving arrangements listed below.

Refrigerator:

24" (61 cm) Wide Models:

With a solid door and door racks. Figure 14.

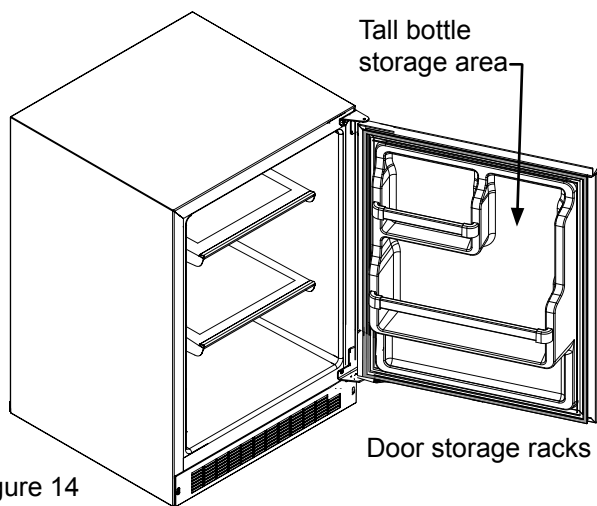

Figure 14

- (2) Full width adjustable steel frame and flat glass cantilever shelf
- (1) Full width door storage rack
- (1) half width door storage rack

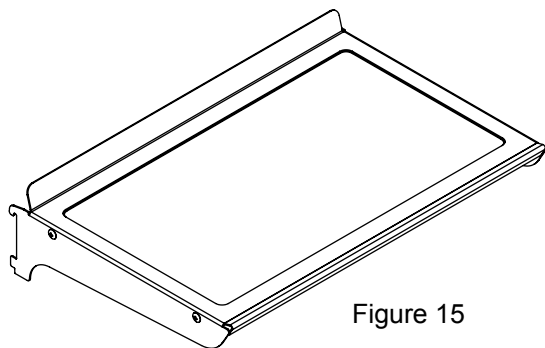

Figure 15

CAUTION

Never try to move a loaded shelf, remove everything from the shelf before moving. Use both hands when moving the shelf.

To Add or Remove a Shelf

Remove stored product from the shelf. Do not try to remove a loaded shelf from the appliance. Grasp the shelf front with both hands, rotate the front upward and lift out. (See Figure 16). To install a shelf insert the shelf in the appliance and insert the top hooks into the shelf support slots and drop the shelf down so the hooks drop over the bottom of the slots.

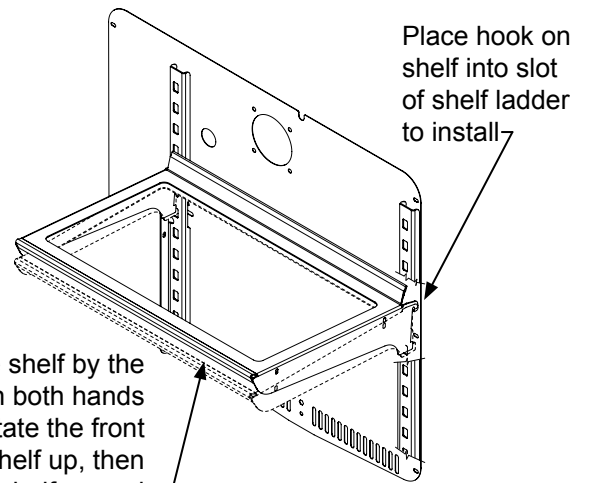

Figure 16

CAUTION

Make sure your cantilever shelf is secure on the shelf supports by pressing down on the shelf before loading.

CARE AND CLEANING

Front Grille

Be sure that nothing obstructs the required air flow openings in front of the cabinet. At least once or twice a year, brush or vacuum lint and dirt from the front grille area (see page 4).



CAUTION

SHOCK HAZARD: Disconnect electrical power from the appliance before cleaning with soap and water.

Cabinet

The stainless steel cabinet can be washed with either a mild soap and water and thoroughly rinsed with clear water. See "Stainless Steel Maintenance" on page 14.

Interior

Wash interior compartment with mild soap and water. Do NOT use an abrasive cleaner, solvent, polish cleaner or undiluted detergent.

Care of Appliance

1. Avoid leaning on the door, you may bend the door hinges or tip the appliance.
2. Exercise caution when sweeping, vacuuming or mopping near the front of the appliance. Damage to the grille can occur.
3. Periodically clean the interior of the appliance as needed.

In the Event of a Power Failure

If a power failure occurs, try to correct it as soon as possible. Minimize the number of door openings while the power is off so as not to adversely affect the appliance's temperature.

Light assembly replacement

All models use LED lamps to illuminate the interior of the appliance. This component is very reliable, but should one fail, contact a qualified service technician for replacement of the LED.



WARNING

Electrocution Hazard

- Never attempt to repair or perform maintenance on the appliance until the main electrical power has been disconnected. Turning the appliance control "OFF" does not remove electrical power from the unit's wiring.
- Replace all parts and panels before operating.

CARE AND CLEANING

Outdoor Product Long-Term Storage / Winterization:

1. Time to Winterize, when the daily low ambient temperature is at or below 38°F (3.3°C).



CAUTION

Operation of the unit at ambient temperatures below the recommended Winterization temperature will void your warranty.

2. Turn unit off, (see page 10)
3. Remove all contents.
4. If necessary, move the unit so you can gain access to the rear of the product.
5. Unplug the unit from the power outlet.
6. It is also recommended that the power to the outlet be turned-off if the circuit is not required for other items during the Winter season.
7. When cleaning unit pay particular attention to any cracks and crevices that may have accumulated dirt and debris.
8. Remove the front toe-grille, (see Figure 17), and use a brush and vacuum to clean dirt and debris from beneath the unit.
9. Thoroughly clean the toe-grille and re-install on the unit. (See Figure 17).
10. Remove the rear access cover, (see Figure 18), and use a brush and vacuum to clean dirt and debris from the machine compartment.
 - If the plastic defrost drain pan located under the compressor contains water, use a sponge to remove as much water as possible.
11. Thoroughly clean the rear access cover and re-install on the unit.
12. Wipe down all interior surfaces with anti-bacterial cleaner to be followed with clean rinse water to remove any residual chemicals which could cause staining. Do not use any abrasive cleaners or scouring pads.
13. Leave the door open and allow to completely dry out before closing the door.
14. Thoroughly clean the door gasket with anti-bacterial cleaner to be followed with clean rinse water to remove any residual chemicals.
15. Thoroughly clean the exterior with a cleaner approved for stainless steel. Do not use any abrasive cleaners or scouring pads. See "Stainless Steel Maintenance" on page 13.
16. Any mounting hardware / fasteners that are showing signs of corrosion should be replaced.
17. Once the exterior has been thoroughly cleaned, you may want to apply a coating of car wax to help protect against spotting from moisture, dirt, and debris that may accumulate on the surfaces during the Winterization period.

18. Do not place a cover on the unit, as this can trap condensation.

After completion of the above, you may choose to store the unit indoors, although this is not required.

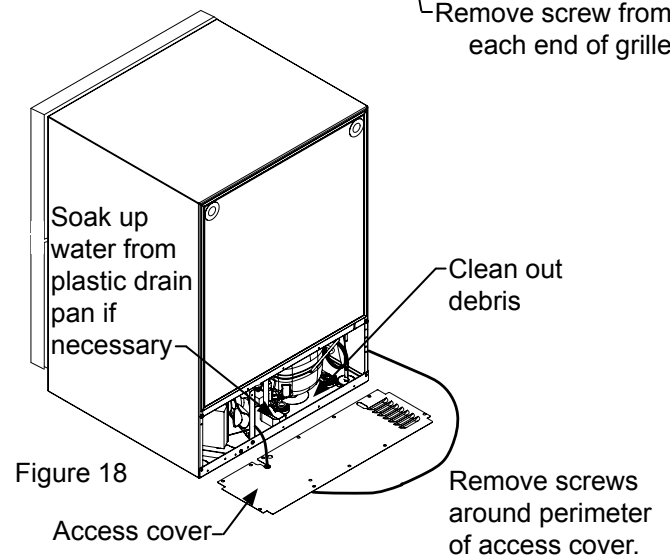
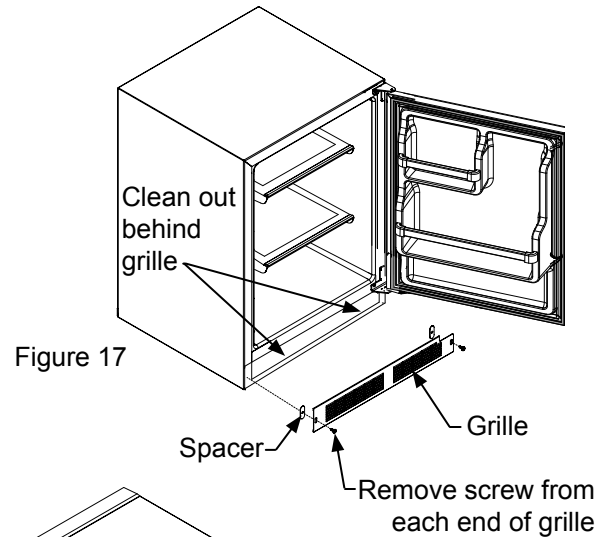

Start-Up After Long-Term Storage:

1. If stored outside, it is recommended that the unit again be thoroughly inspected per the storage instructions above to address any dirt or debris from the weather and/or animals/insects.
2. Connect the unit to electrical power.
3. Turn unit on and confirm your desired control settings.
4. Allow 24-hrs for the unit to stabilize before loading contents.

STAINLESS STEEL MAINTENANCE AND ENERGY SAVING TIPS

Background

Stainless steel does not stain, corrode, or rust as easily as ordinary steel, but it is not stain or corrosion proof. Stainless steels can discolor or corrode if not maintained properly.

Stainless steels differ from ordinary carbon steels by the amount of chromium present. It is this chromium that provides an invisible protective film on the surface called chrome-oxide. This protective chrome-oxide film on the surface can be damaged or contaminated, which may result in discoloration, staining, or corrosion of the base metal.

Care & Cleaning

Routine cleaning of the stainless steel surfaces will serve to greatly extend the life of your product by removing contaminants. This is especially important in coastal areas which can expose the stainless to severe contaminants such as halide salts, (sodium chloride).

It is strongly recommended to periodically inspect and thoroughly clean crevices, weld points, under gaskets, rivets, bolt heads, and any locations where small amounts of liquid could collect, become stagnant, and concentrate contaminants. Additionally, any mounting hardware that is showing signs of corrosion should be replaced.

Frequency of cleaning will depend upon the installation location, environmental, and usage conditions.

Choosing a Cleaning Product

The choice of a proper cleaning product is ultimately that of the consumer, and there are many products from which to choose. Depending upon the type of cleaning and the degree of contamination, some products are better than others.

Typically the most effective and efficient means for routine cleaning of most stainless steel products is to give the surfaces a brisk rubbing with a soft cloth soaked in warm water and a gentle detergent, or mild mixture of ammonia. Rubbing should, to the extent possible, follow the polish lines of the steel, and always insure thorough rinsing after cleaning.

Although some products are called "stainless steel cleaners," some may contain abrasives which could scratch the surface, (compromising the protective chrome-oxide film), and some many contain chlorine bleach which will dull, tarnish or discolor the surface if not completely removed.

After the stainless surfaces have been thoroughly cleaned, a good quality car wax may be applied to help maintain the finish.

NOTE

Stainless steel products should never be installed, or stored in close proximity to chlorine chemicals.

Whichever cleaning product you chose, it should be used in strict accordance with the instructions of the cleaner manufacturer.

Energy saving tips:

The following suggestions will minimize the cost of operating your refrigeration appliance.

1. Do not install your appliance next to a hot appliance (cooker, dishwasher, etc.), heating air duct, or other heat sources.
2. Install product out of direct sunlight.
3. Ensure the front grille vents at front of appliance beneath door are not obstructed and kept clean to allow ventilation for the refrigeration system to expel heat.
4. Plug your appliance into a dedicated power circuit. (Not shared with other appliances).
5. When initially loading your new product, or whenever large quantities of warm contents are placed within refrigerated storage compartment, minimize door openings for the next 12 hours to allow contents to pull down to compartment set temperature.
6. Maintaining a relatively full storage compartment will require less appliance run time than an empty compartment.
7. Ensure door closing is not obstructed by contents stored in your appliance.
8. Allow hot items to reach room temperature before placing in product.
9. Minimize door openings and duration of door openings.
10. Use the warmest temperature control set temperature that meets your personal preference and provides the proper storage for your stored contents.
11. When on vacation or away from home for extended periods, set the appliance to warmest acceptable temperature for the stored contents.
12. Set the control to the "off" position if cleaning the appliance requires the door to be open for an extended period of time.

TROUBLESHOOTING

Before You Call for Service

If the appliance appears to be malfunctioning, read through this manual first. If the problem persists, check the troubleshooting guide below. Locate the problem in the guide and refer to the cause and its remedy before calling for service. The problem may be something very simple that can be solved without a service call. However, it may be required to contact your dealer or a qualified service technician.



In the unlikely event you lose cooling in your unit, **do not unplug the product from the electric supply**, but do call a qualified service technician immediately. It is possible that the loss of cooling capacity is a result of excessive frost build-up on the evaporator cooling coil. In this case, removing power to the unit will result in the melting of this excessive quantity of ice, which could generate melt water that exceeds the capacity of the defrost drain system and could result in water damage to your home. The end-user will be ultimately responsible for any water damage caused by prematurely turning the unit off without appropriately managing the excess water run-off.

WARNING

Electrocution Hazard

- Never attempt to repair or perform maintenance on the appliance until the main electrical power has been disconnected. Turning the appliance control "OFF" does not remove electrical power from the unit's wiring.
- Replace all parts and panels before operating.

Problem	Possible Cause	Remedy
Appliance not cold enough (See "Adjusting the temperature" on page 9)	<ul style="list-style-type: none"> Control set too warm Content temperature not stabilized. Excessive usage or prolonged door openings. Airflow to front grille blocked. Door gasket not sealing properly. 	<ul style="list-style-type: none"> Adjust temperature colder. Allow 24 hours for temperature to stabilize. Allow temperature to stabilize for at least 24 hours. Airflow must not be obstructed to front grille. See "clearances" on page 4. Replace door gasket.
Appliance too cold (See "Adjusting the Temperature" on page 9)	<ul style="list-style-type: none"> Control set too cold Door gasket not sealing properly. 	<ul style="list-style-type: none"> Adjust temperature warmer. Allow 24 hours for temperature to stabilize. Replace door gasket.
No interior light.	<ul style="list-style-type: none"> Failed LED light assembly or light switch. 	<ul style="list-style-type: none"> Contact a qualified service technician.
Light will not go out when door is closed	<ul style="list-style-type: none"> Door not activating light switch. Failed light switch 	<ul style="list-style-type: none"> Appliance not level, level appliance, (See page 4, "leveling legs") Contact a qualified service technician.
Noise or Vibration	<ul style="list-style-type: none"> Appliance not level Fan hitting tube obstruction. 	<ul style="list-style-type: none"> Level appliance, see "Leveling Legs" on page 4. Contact a qualified service technician.
Appliance will not run.	<ul style="list-style-type: none"> Appliance turned off Power cord not plugged in. No power at outlet. 	<ul style="list-style-type: none"> Turn appliance on. See "Starting your appliance" on page 9. Plug in power cord. Check house circuit.

WARRANTY

Peterson Fire Magic Limited Warranty

What is covered and for how long?

This warranty covers all defects in workmanship or materials for a period of:

12 months parts

The warranty commences on the date the item was purchased and the original purchase receipt must be presented to the authorized service center before warranty repairs are rendered.

What is covered?

The mechanical and electrical parts, which serve as a functional, purpose of this appliance for a period of 12 months. This includes all parts except finish, and trim.

What will be done?

1. We will repair or replace, at our discretion any mechanical or electrical part which proves to be defective in normal usage during the warranty period so specified.
2. There will be no charge to the purchaser for parts on any covered items during the initial 12 month period.
3. This warranty does not cover labor or labor related charges, except as provided by separate specific written programs from the Peterson Co. All repair work must be performed by a qualified professional service person and requires prior approval of Peterson.
4. Contact your nearest authorized Fire Magic Dealer. For the name of the nearest Fire Magic Dealer please call 1-626-369-5085.

THIS WARRANTY DOES NOT COVER THE FOLLOWING:

Damages from improper installation.
Damages in shipping.
Defects other than manufacturing.
Damage from misuse, abuse, accident, alteration, lack of proper care and maintenance or incorrect current or voltage.
Damage from other than household use.
Damage from service by other than an authorized dealer or service center. Decorative trims or replaceable light bulbs.
Transportation and shipping.

THIS LIMITED WARRANTY IS GIVEN IN LIEU OF ALL OTHER WARRANTIES, EXPRESSED OR, INCLUDING THE WARRANTIES OF MERCHANTABILITY AND FITNESS FOR A PARTICULAR PURPOSE.

The remedy provided in this warranty is exclusive and is granted in lieu of all other remedies.

This warranty does not cover incidental or consequential damages, so the above limitations may not apply to you. Some States do not allow limitations on how long an implied warranty lasts, so the above limitations may not apply to you. This warranty gives you specific legal rights, and you may have other rights, which vary, from state to state.

Fire Magic
14724 East Proctor Ave
City of Industry, CA 91746

