Installation, Operation and maintenance Instructions

Kegeerator

3594-DR

3594-DL

FIREMAGIC

CONTENTS

Contents:

Safety information	2
Unpacking your appliance	3
Installing your appliance	4
Cabinet clearances	4
Leveling the appliance	4
Electrical connection	5
Installing the anti-tip device	6
Product dimensions	8
Using your Electronic control	9
Starting your appliance	9
Turning your appliance "ON" or "OFF"	9
Adjusting the temperature	9
Kegeator operation	9
Alarms	9
Door ajar	9
Temperature sensor fault	9
High and low temperature alarm	9
Alarm mute ..	9
Using your kegeator.....	10
Shelving	10
Tap equipment and assembly.....	11
CO ₂ regulator	15
Drain kit	16
Care and cleaning	16
Cleaning the drain sump	16
Keg coupler cleaning	17
Faucet cleaning	17
Tap cleaning kit	18
Cleaning the beer line	18
Front grille	18
Cabinet	18
Interior	18
Long term storage / winterization	19
Stainless steel maintenance	21
Energy saving tips	21
Troubleshooting	22
Warranty	23

Important Safety Instructions

Warnings and safety instructions appearing in this guide are not meant to cover all possible conditions and situations that may occur. Common sense, caution, and care must be exercised when installing, maintaining, or operating this appliance.

Recognize Safety Symbols, Words, and Labels.

WARNING

WARNING - You can be killed or seriously injured if you do not follow these instructions.

CAUTION

CAUTION-Hazards or unsafe practices which could result in personal injury or property / product damage.

NOTE

NOTE-Important information to help assure a problem free installation and operation.



Energy Verified

MC233973

Certified to:
Household Refrigerators and Freezers
CSA C22.2 No.63

Refrigeration Equipment
CAN/CSA C22.2 No.120

Safety of Household and Similar Appliances
CAN/CSA C22.2 No.60335-1

Safety of Household and Similar Electrical Appliances
CAN/CSA C22.2 No.60335-2-24

WARNING

State of California Proposition 65 Warning:
This product contains one or more chemicals known to the State of California to cause cancer.

WARNING

State of California Proposition 65 Warning:
This product contains one or more chemicals known to the State of California to cause birth defects or other reproductive harm..

UNPACKING YOUR APPLIANCE



WARNING

EXCESSIVE WEIGHT HAZARD

Use two or more people to move product.
Failure to do so can result in personal injury.

Remove Interior Packaging

Your appliance has been packed for shipment with all parts that could be damaged by movement securely fastened. Remove internal packing materials and any tape holding internal components in place. The owners manual is shipped inside the product in a plastic bag along with the warranty registration card, and other accessory items.

Important

Keep your carton and packaging until your appliance has been thoroughly inspected and found to be in good condition. If there is damage, the packaging will be needed as proof of damage in transit. Afterwards please dispose of all items responsibly.



WARNING

WARNING - Dispose of the plastic bags which can be a suffocation hazard.

FIREMAGIC		 C Energy Verified US MC233973 REFRIGERATOR OUTDOOR RATED			
CITY OF INDUSTRY, CA 91746					
MODEL NO.	<input type="text"/>				
SERVICE NO.	<input type="text" value="XXXXXXXXXXXX"/>				
SERIAL NO.	<input type="text" value="XXXXXXXXXXXX"/>				
HZ <input type="text"/>	VOLTS <input type="text"/>	AMPS <input type="text"/>	R134A	<input type="text"/>	oz
TEST PRESSURE 140 PSI LOW SIDE 300 PSI HIGH SIDE					

Figure 1

Note to Customer

This merchandise was carefully packed and thoroughly inspected before leaving our plant. Responsibility for its safe delivery was assumed by the retailer upon acceptance of the shipment. Claims for loss or damage sustained in transit must be made to the retailer.

NOTE

DO NOT RETURN DAMAGED MERCHANDISE TO THE MANUFACTURER - FILE THE CLAIM WITH THE RETAILER.



CAUTION

If the appliance was shipped, handled, or stored in other than an upright position for any period of time, allow the appliance to sit upright for a period of at least 24 hours before plugging in. This will assure oil returns to the compressor. Plugging the appliance in immediately may cause damage to internal parts.



WARNING

WARNING - Help Prevent Tragedies

Child entrapment and suffocation are not problems of the past. Junked or abandoned refrigerators are still dangerous - even if they sit out for "just a few hours".

If you are getting rid of your old refrigerator, please follow the instructions below to help prevent accidents.

Before you throw away your old refrigerator or freezer:

- Take off the doors or remove the drawers.
- Leave the shelves in place so children may not easily climb inside.

INSTALLING YOUR APPLIANCE

Select Location

The proper location will ensure peak performance of your appliance. We recommend a location where the unit will be out of direct sunlight and away from heat sources. To ensure your product performs to specifications, the recommended installation location temperature range is from 55 to 115°F (13 to 46°C).

Cabinet Clearance

Ventilation is required from the bottom front of the appliance. Keep this area open and clear of any obstructions. Adjacent cabinets and counter top can be installed around the appliance as long as the front grille remains unobstructed.

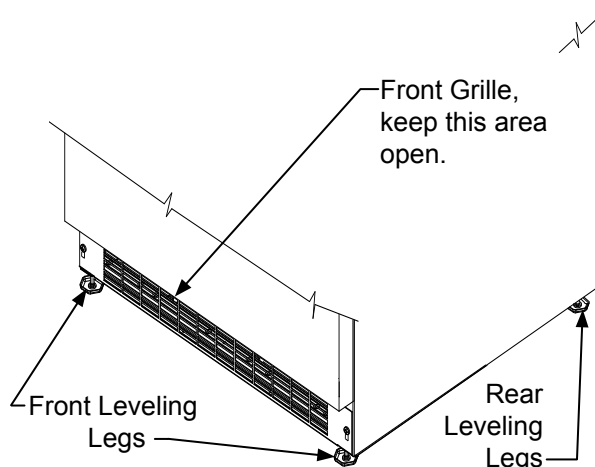

Figure 2

Leveling Legs

Adjustable legs at the front and rear corners of the appliance should be set so the unit is firmly positioned on the floor and level from side to side and front to back. The overall height of your appliance may be adjusted between the minimum, 33³/₄" (85.7 cm), by turning the leveling leg in (CW ↻) and the maximum, 34³/₄" (88.3 cm) by turning the leveling leg out (CCW ↻).

To adjust the leveling legs, place the appliance on a solid surface and protect the floor beneath the legs to avoid scratching the floor. With the assistance of another person, lean the appliance back to access the front leveling legs. Raise or lower the legs to the required dimension by turning the legs. Repeat this process for the rear by tilting the appliance forward using caution. On a level surface check the appliance for levelness and adjust accordingly.

The front grille screws may be loosened and the grille adjusted to the desired height. When adjustment is complete tighten the two front grille screws. (See Figure 5).



CAUTION

Front Grille

Do not obstruct the front grille. The openings within the front grille allow air to flow through the condenser heat exchanger. Restrictions to this air flow will result in increased energy usage and loss of cooling capacity. For this reason it is important this area not be obstructed and the grille openings kept clean. Firemagic does not recommend the use of a custom made grille as air flow may be restricted. (See Figure 2).

INSTALLING YOUR APPLIANCE

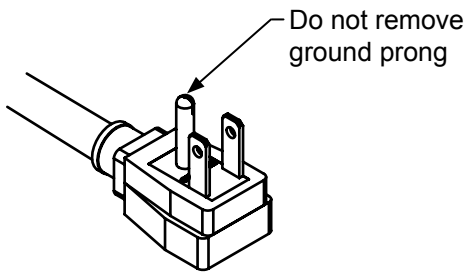

Figure 3

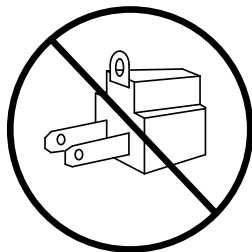

Figure 4

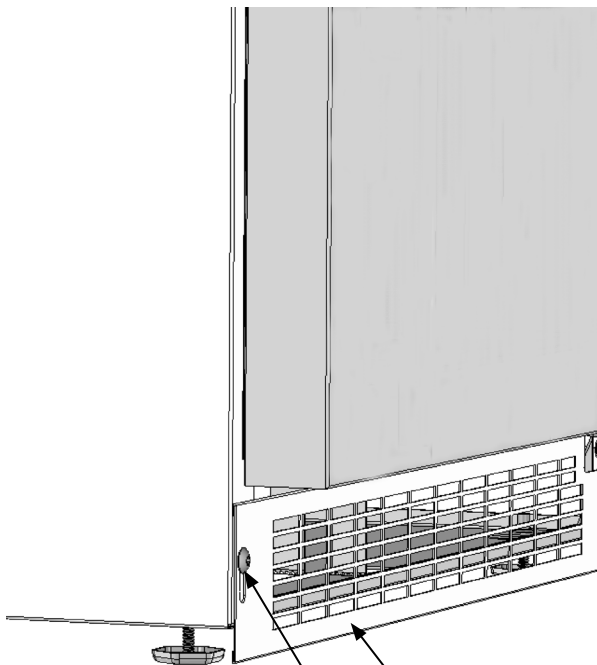

Figure 5

Front grille
Front grille screw

WARNING

Electrical Shock Hazard

- Do not use an extension cord with this appliance. They can be hazardous and can degrade product performance.
- This appliance should not, under any circumstances, be installed to an un-grounded electrical supply.
- Do not remove the grounding prong from the power cord. (See Figure 3).
- Do not use an adapter. (See Figure 4).
- Do not splash or spray water from a hose on the appliance. Doing so may cause an electrical shock, which may result in severe injury or death.

Electrical Connection

A grounded 115 volt, 15 amp dedicated circuit is required.

This product is factory equipped with a power supply cord that has a three-pronged, grounded plug. It must be plugged into a mating grounding type receptacle in accordance with the National Electrical Code and applicable local codes and ordinances (see Figure 6). If the circuit does not have a grounding type receptacle, it is the responsibility and obligation of the customer to provide the proper power supply. The third ground prong should not, under any circumstances, be cut or removed.

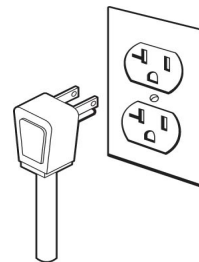



Figure 6

NOTE

Ground Fault Circuit Interrupters (GFCI) are prone to nuisance tripping which will cause the appliance to shut down. GFCI's are generally not used on circuits with power equipment that must run unattended for long periods of time, unless required to meet local building codes and ordinances.

INSTALLING THE ANTI TIP DEVICE FOR FREESTANDING INSTALLATIONS

!
WARNING



- ALL APPLIANCES CAN TIP RESULTING IN INJURY.
- INSTALL THE ANTI-TIP BRACKET PACKED WITH THE APPLIANCE.
- FOLLOW THE INSTRUCTIONS BELOW

!
WARNING

If your refrigerator is not located under a counter top (free standing), you must use an anti-tip device installed as per these instructions. If the refrigerator is removed from its location for any reason, make sure that the device is properly engaged with the anti-tip bracket when you push the refrigerator back into the original location. If the device is not properly engaged, there is a risk of the refrigerator tipping over, with the potential for property damage or personal injury.

NOTE

If installing on a concrete floor, concrete fasteners are required, (not included with the anti-tip kit).

!
CAUTION

Any finished flooring should be protected with appropriate material to avoid damage when moving the unit.

Floor Mount Installation

The anti-tip bracket is to be located on the floor in the left or right rear corner of the kegerator as shown in Figure 7.

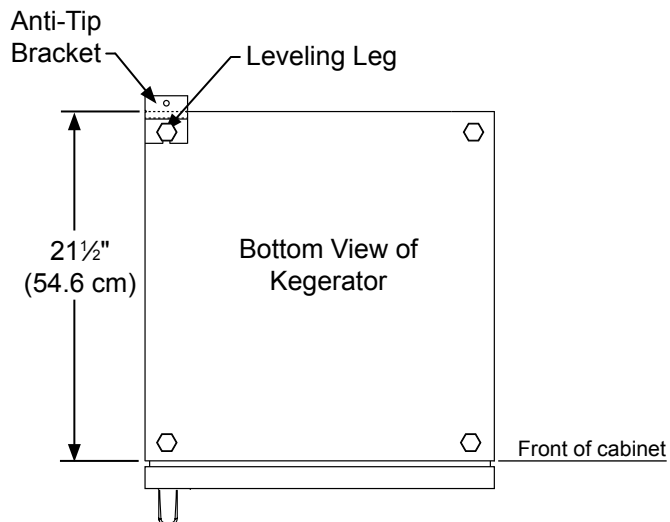

Figure 7

Step by step instructions for locating the position of the bracket:

- 1) Decide where you want to place the kegerator. Slide it into place, being careful not to damage the floor, leaving 1" (2.5 cm) of clearance from the rear wall to allow room for the anti-tip bracket.
- 2) Raise the rear leveling legs approximately 1/4" (6 mm) to allow engagement with the anti-tip bracket. Level the unit by adjusting all the leveling legs as required. Turning the leveling leg counterclockwise will raise the unit and clockwise will lower the unit.
- 3) Make sure the kegerator is in the desired location, then mark on the floor the rear and side corner of the cabinet where the anti-tip bracket will be installed. If the installation does not allow marking the rear corner of the cabinet, then make temporary lines on the floor marking the front corner of the cabinet, excluding the door. Slide the kegerator out of the way. From the temporary line extend the sidewall line back 21 1/2" (54.6 cm) as shown in Figure 8.
- 4) Align the anti-tip bracket to the marks on the floor so the side of the bracket lines up with the side of the cabinet mark, and the "V" notches on the anti-tip bracket line up with the end of the 21 1/2" (54.6 cm) line (Rear of cabinet line).
- 5) Fasten the anti-tip bracket to the floor using the supplied screw. (See Figure 8).
- 6) Slide the cabinet back into position, making sure the rear cabinet leveling leg slides under the anti-tip bracket engaging the slot.

INSTALLING THE ANTI TIP DEVICE FOR FREESTANDING INSTALLATIONS

NOTE

When the floor mounted anti-tip bracket is used the minimum adjusted height of the cabinet is increased by $\frac{3}{8}$ " (9 mm).

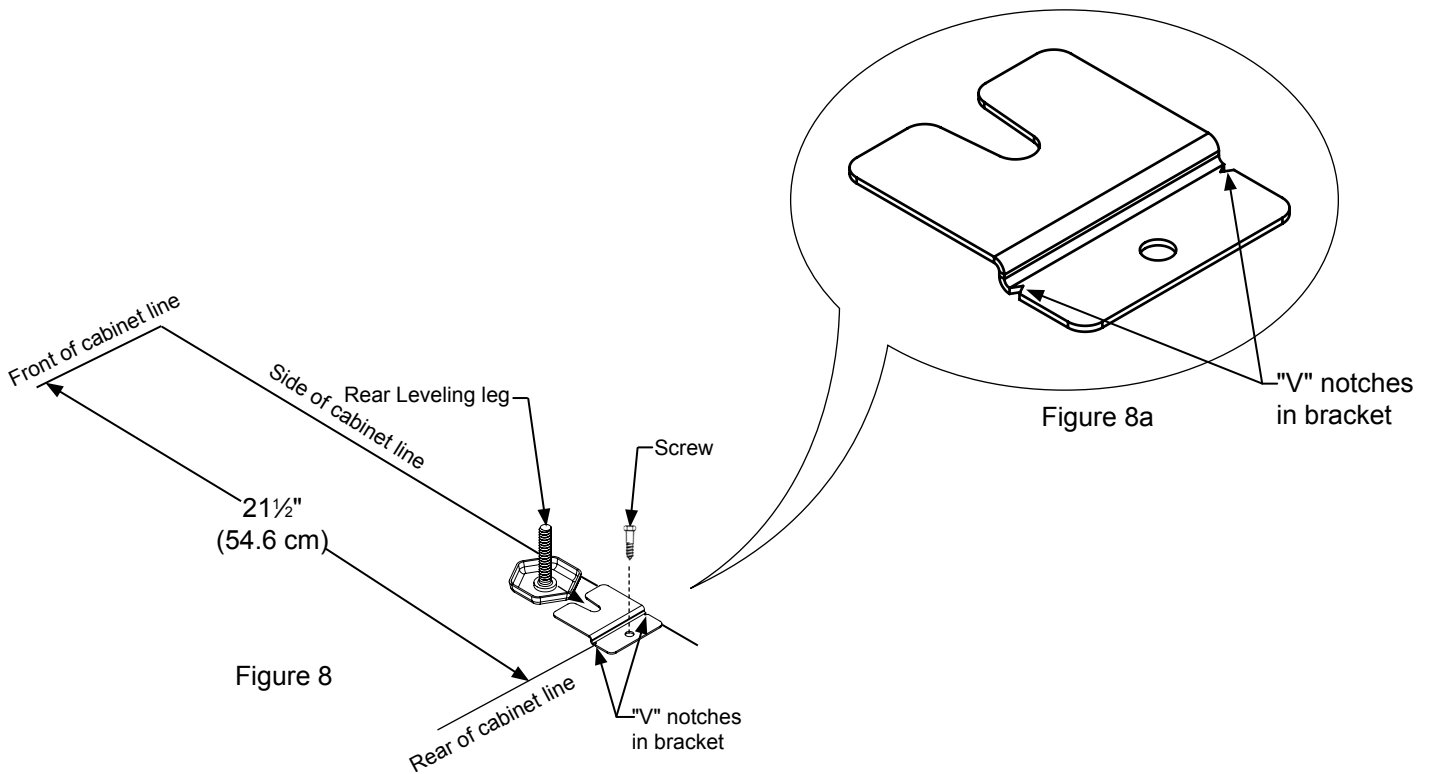

PRODUCT DIMENSIONS 3594-DR AND 3594-DL

MODEL	ROUGH-IN OPENING DIMENSIONS			CABINET DIMENSIONS					
	"A"	"B"	"C"	"D"	"E"	"F"	"G"	"H"	"J"
3594-DR 3594-DL	24.5" (62 cm)	**34" to 35" (86.4 to 88.9 cm)	*	23 ⁷ / ₈ " (60.7 cm)	33 ³ / ₄ " to 34 ³ / ₄ " (85.7 to 88.3 cm)	23 ²³ / ₃₂ " (60.2 cm)	26 ¹ / ₃₂ " (66.9 cm)	46 ¹³ / ₃₂ " (117.9 cm)	26 ⁹ / ₁₆ " (67.5 cm)

PRODUCT DATA		
MODEL	ELECTRICAL REQUIREMENTS#	PRODUCT WEIGHT
3594-DR 3594-DL	115V/60Hz/15A	140 lbs (63.6 kg)

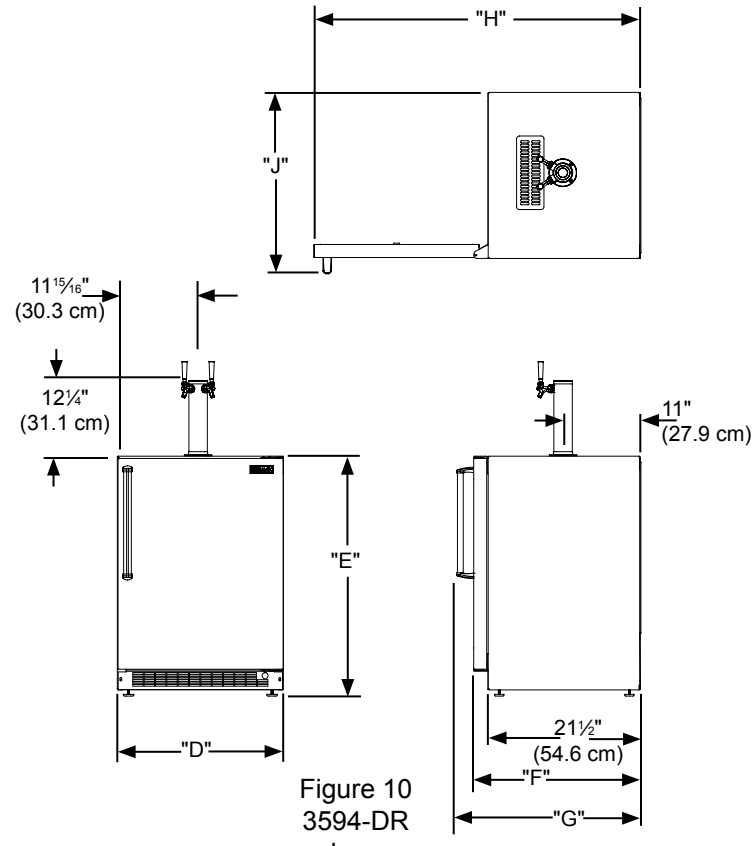
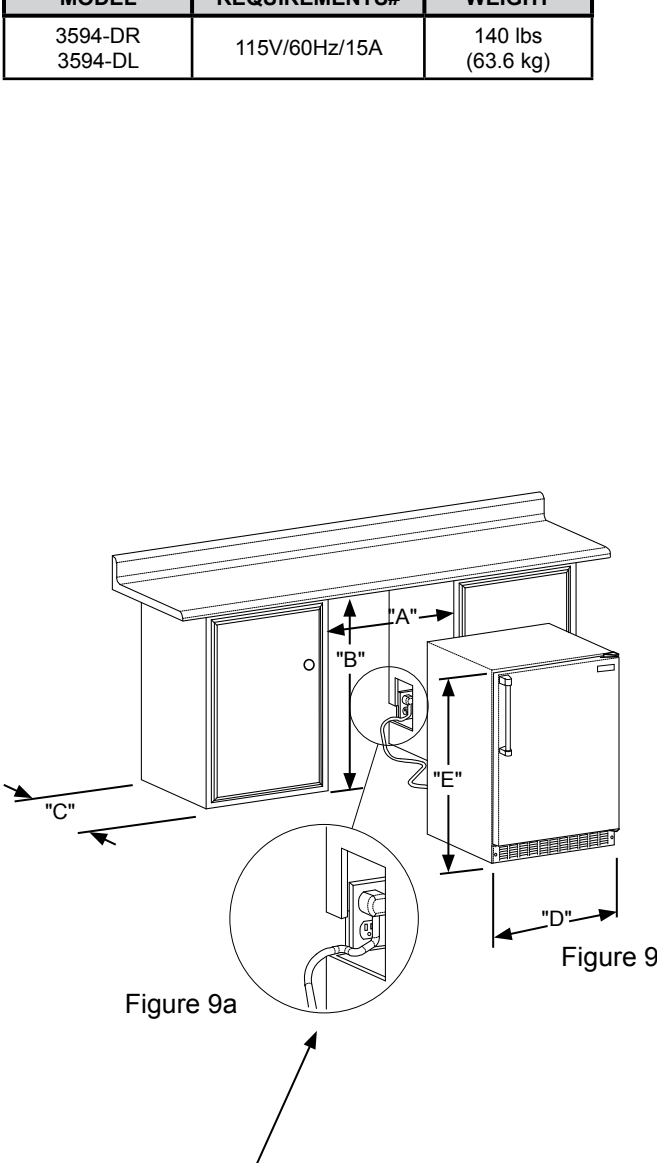

If necessary to gain clearance inside the rough-in opening a hole can be cut through the adjacent cabinet and the power cord routed through this hole to a power outlet. Another way to increase the available opening depth is to recess the power outlet into the rear wall to gain the thickness of the power cord plug. Not all recessed outlet boxes will work for this application as they are too narrow, but a recessed outlet box equivalent to Arlington #DVFR1W is recommended for this application, (see Figure 11).

* Depth dimension of rough-in opening may vary depending on each individual installation. To recess entire door "F" dimension plus 1" (2.5 cm) for thickness of power cord plug is required.

** Minimum rough-in opening required is to be larger than the adjusted height of the cabinet.

A grounded 15 amp dedicated circuit is required. Follow all local building codes when installing electrical and appliance.

USING YOUR ELECTRONIC CONTROL

Figure 12 close-up of control

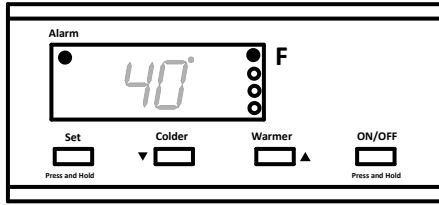

Starting your kegerator

Plug the kegerator power cord into a wall outlet. Your kegerator will begin cooling after power is applied. If your kegerator does not start, check that the kegerator is turned on and the set temperature is cold enough.

Turning your kegerator ON or OFF

If the kegerator is on, the kegerator temperature will be shown on the display. To turn the kegerator off, press and hold the "ON/OFF" button for three (3) seconds. "OFF" will appear on the display.

If the kegerator is not on, "OFF" will be shown on the display. To turn the kegerator on, press and hold the "ON/OFF" button for three (3) seconds. The kegerator temperature will be shown on the display.

Set temperature

To set the kegerator temperature, press and hold the "SET" button. When the "SET" button is pressed, the display will show the set temperature. While holding the "SET" button, press the "WARMER" or "COLDER" buttons to adjust set temperature.

Kegerator operation

The available temperature range of the kegerator is 34° to 46°F (1° to 8° C).

It may take up to 24 hours for your kegerator to reach desired temperature. This will depend on amount of content loaded and number of door opening and closings.

For best results allow kegerator to "pull down" to desired set temperature before loading. Once contents are loaded, allow at least 48 hours for temperature to stabilize before making any adjustments to the set temperature.

Alarms

Your electronic control will monitor kegerator function and alert you with a series of audible and visual alarms.



• **Door Ajar Alarm:** If the door has been left open for over five (5) minutes, the alarm will sound in one (1) second intervals. The display panel will flash "do" and the Alarm LED located at the top left of the display below the word "Alarm" will be illuminated. This will stop as soon as the door is closed.

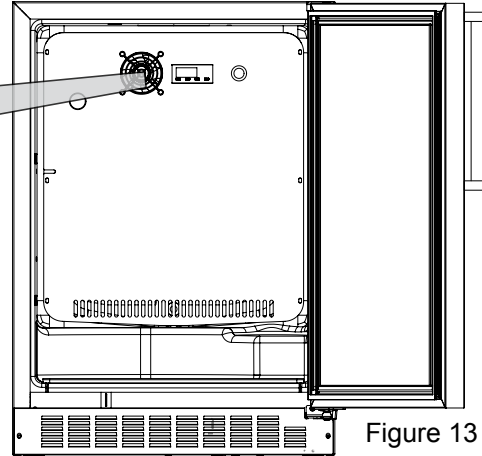

Figure 13



• **Temperature Sensor Fault:** If the controller detects that the temperature sensor is not properly functioning, a temperature sensor alarm will sound in one (1) second intervals. "E1" will flash on the display panel and the Alarm LED located at the top left of the display below the word "Alarm" will be illuminated. Please call Firemagic Customer Service or your dealer if this error code is displayed.



• **High and Low Temperature Alarm:** If the storage compartment temperature deviates excessively from the set-point temperature, the alarm will sound in (1) second intervals. The display panel will flash either "Hi" or "Lo" depending upon the condition and the Alarm LED light at the top left of the display below the word "Alarm" will be illuminated. The alarm will remain active until the condition is corrected.

NOTE

After a high temperature alarm condition, check all perishables to ensure they are safe for consumption.

NOTE

The temperature alarm may occur as a result of high usage or introduction of warm contents to the storage compartment. If the temperature alarm continues to occur, your unit may require service.

Alarm Mute

Press any key to mute the audible portion of an alarm.

NOTE

This action will only mute the alarm. If the condition that caused the alarm continues, the alarm code will continue to flash and will sound for 20 seconds every 60 minutes.

USING YOUR KEGERATOR

Shelving

The unit is shipped with the (2) shelves taped in place in the upper and the lower shelf positions. Remove them from the refrigerator and arrange them as follows when setting up your unit.

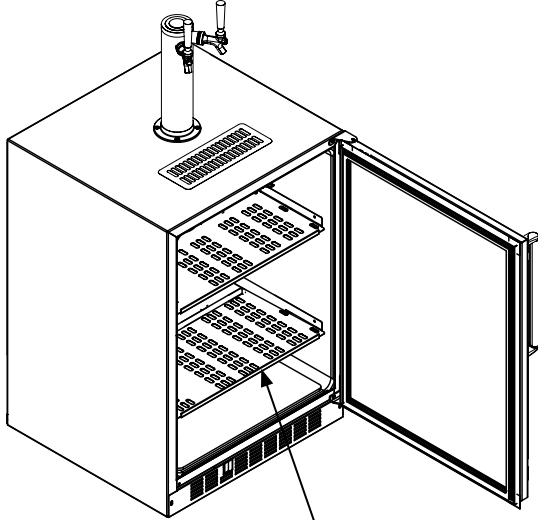

Figure 14 Two stainless steel shelves

If you are not serving beer on tap, your kegerator can be used as a refrigerator by placing both shelves on the mounting brackets as shown in Figure 15. The shelves are marked upper and lower. The upper shelf should be placed in the top shelf position and the shelf marked lower should be placed in the bottom shelf position.



If you are using the appliance as a refrigerator for perishable foods, the set-point temperature should be set between 34°F and 42° F (1.2° C and 5.7° C).

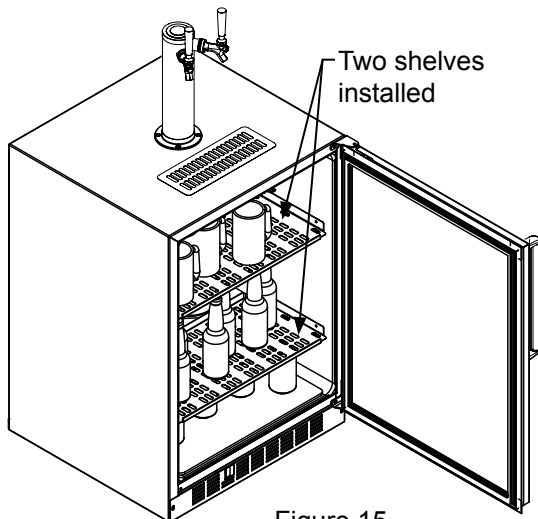

Figure 15

If you are using a quarter barrel of beer, you can add shelf space for keeping your mugs chilled. The quarter barrel must set on the floor, it cannot fit on the shelf, see Figure 16. Be sure the white floor plate is in the bottom of the interior compartment before positioning the barrel.

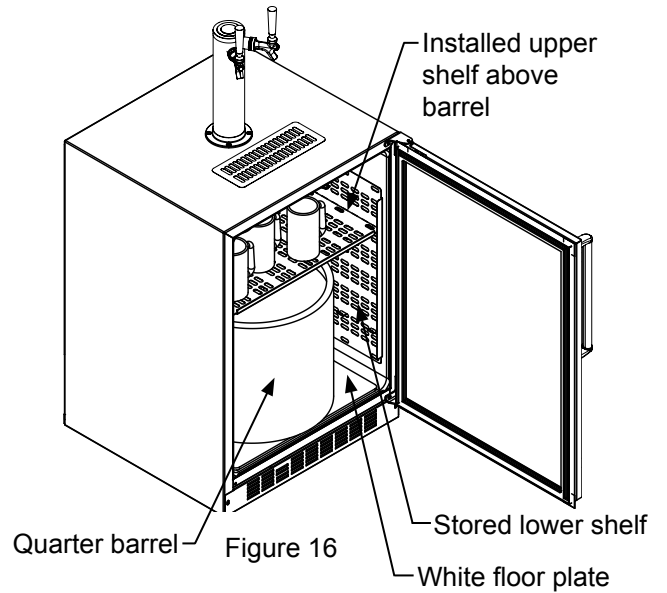

Figure 16

If you are using a half barrel (keg) or (2) 1/6 barrels, place the two shelves on the right side of the kegerator on the two mounting hooks for storage. (See Figure 17). Be sure the white floor plate is in the bottom of the interior compartment before positioning the barrel(s).

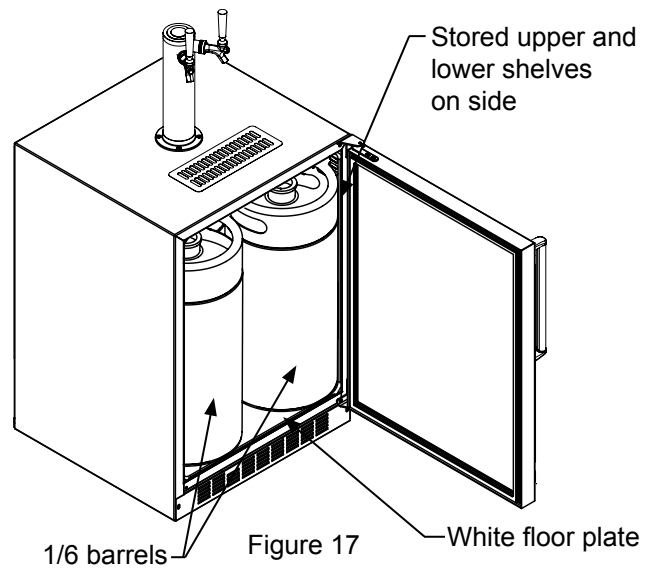

Figure 17

USING YOUR KEGERATOR

This beer dispensing unit will support one half (½) barrel or one quarter (¼) barrel. The double draft tower units can support two sixth (⅙) barrels of beer. See chart below for quantity of beer in each barrel size.

	Barrel Sizes		
	1/6 barrel	1/4 Barrel	1/2 Barrel
Height	23 ⁵ / ₁₆ " (59.2 cm)	14 ¹³ / ₁₆ " (37.6 cm)	23 ⁵ / ₁₆ " (59.2 cm)
Diameter	9 ¹ / ₄ " (23.5 cm)	17" (43.2 cm)	17" to 17 ¹ / ₄ " (43.2 to 43 cm)
Gallons	5.16	7.75	15.5
#12 ounce Glasses	60	82	163

Table A

Keg Size	#of kegs per 5 pound CO ₂ Tank
5 gallon Corny	15 to 22
1/6 barrel	14 to 21
1/4 Barrel	10 to 14
1/2 Barrel	5 to 7

Table B

Tools required for installation:

- Flat bladed screwdriver
- Phillips screwdriver
- Pliers
- Adjustable wrench or a 1½" open end wrench
- ½" open end wrench



WARNING

CO₂ can be dangerous. If it becomes difficult to breathe and/or your head starts to ache, a high concentration of carbon dioxide may be present. Leave the area immediately.

- The CO₂ tank must always be connected to the regulator. **Never** connect the tank to the keg.
- The CO₂ tank must be securely mounted in the upright position. Secure it with the chain provided.
- **Never** drop or throw the CO₂ tank.
- Keep the CO₂ tank away from heat.
- Ventilate the area after a CO₂ leak.

1. Remove shelving and packaged components from the interior of the refrigerator before beginning the assembly process.
2. Take your empty 5 pound CO₂ tank to your local gas supply dealer to be filled. You can usually find them in your "yellow pages" under "Welding Supply" or "Fire Protection". One 5 pound tank can process many kegs (see table "B").
3. Tower mounting (if you are installing the unit under a counter skip to step 4). If you are mounting the tower directly to the top of the refrigerator, first remove the four screws from the top of the refrigerator. Remove the foam plug from the large hole in the top of the refrigerator. Feed the clear beer line through the tower gasket and the large hole in the refrigerator top. Align the 4 holes in the tower with the 4 holes in the refrigerator top and secure the tower with the 4 screws removed previously. Skip to step 5.

Tap Equipment and Assembly

Your dispensing kit includes the following parts:

- Polished stainless steel tower with clear beer line (single or double dispense)
- Tower Gasket
- Phillips oval head screws
- Knob for Tower (Faucet Handle)
- Keg coupler(s)
- CO₂ regulator with red gas line(s) attached
- Empty 5 pound CO₂ tank
- Plastic clamp(s) large and small
- Faucet wrench

USING YOUR KEGERATOR

Double Dispense Tower Kit

Connect **A** to **A**, etc.....

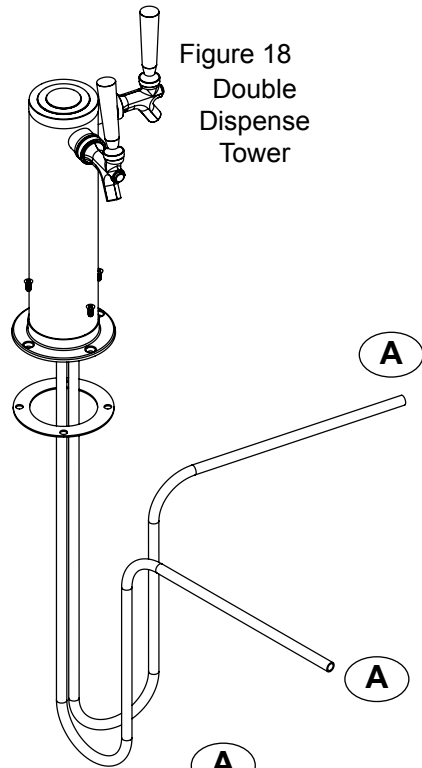
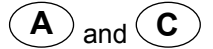

Figure 19



Hose clamps
use for connections



Keg
Coupler



Figure 20



Keg
Coupler
Figure 21

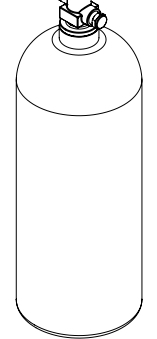

5 Pound
CO₂ Tank

Figure 22

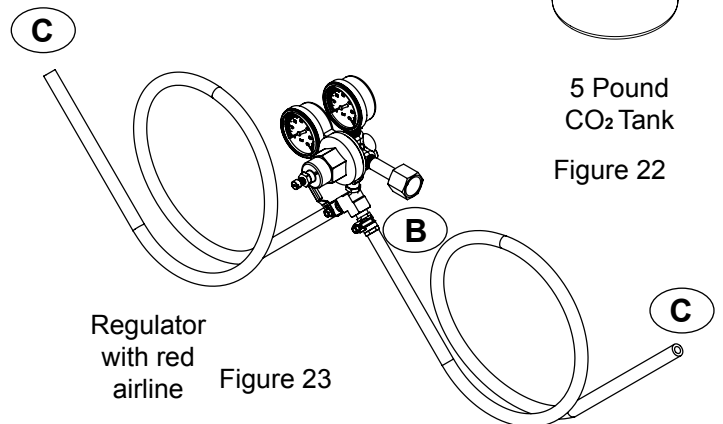

USING YOUR KEGERATOR

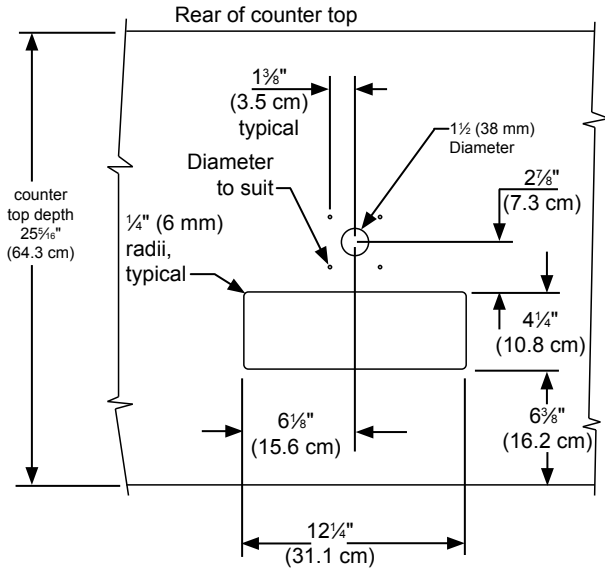

Figure 24



CAUTION

The cutout dimensions shown in Figure 24 are based on a 25 $\frac{5}{16}$ " (64.3 cm) deep counter top. Your counter top may be different than this and require other front to back dimensioning. Refer to the product dimensions on page 8 when determining the required dimensions.

- If you are installing your keg refrigerator under a counter you will need to drill 5 holes in the counter top to mount the tower. The first hole is a 1 $\frac{1}{2}$ " diameter hole located at the center of the tower for the beer line, locate approximately 13 $\frac{1}{2}$ " (34.3 cm) from the front edge of the counter top (based on a counter top depth of 25 $\frac{5}{16}$ "). Next drill the 4 tower mounting holes per the dimensions in Figure 24. The hole diameter is dependent on the counter top material and if screw anchors are required. The screws supplied are in the literature pack and are a #10 x 1" type AB stainless steel screw. Mark and cut the rectangular cutout for the drain sump. After the holes are drilled and the keg refrigerator is in place under the counter top feed the beer line through the tower gasket, the 1 $\frac{1}{2}$ " hole in the counter top and the hole in the top of the keg refrigerator. Mount the tower to the counter top with the 4 screws provided. Place the counter top drain sump, from the literature pack, in the rectangular hole with the radius cutout to the rear around the tower and place the grate in the sump.
- Mount the regulator to the CO₂ tank (connection **B**). Note that the regulator has left hand threads and has to be turned counterclockwise to tighten. Tighten with the adjustable wrench or the 1 $\frac{1}{8}$ " open end wrench.
- Connect the red air line(s) from the regulator to the **large** air line fitting on the keg coupler with a **large** hose clamp (connection **C**).
- Connect the clear beer line from the tower to the **small** air line fitting on the keg coupler with a **small** hose clamp (connection **A**).
- Locate the CO₂ tank in the corner of the refrigerator as shown in Figure 27 and secure with the chain. Close the faucet handle on the tower.

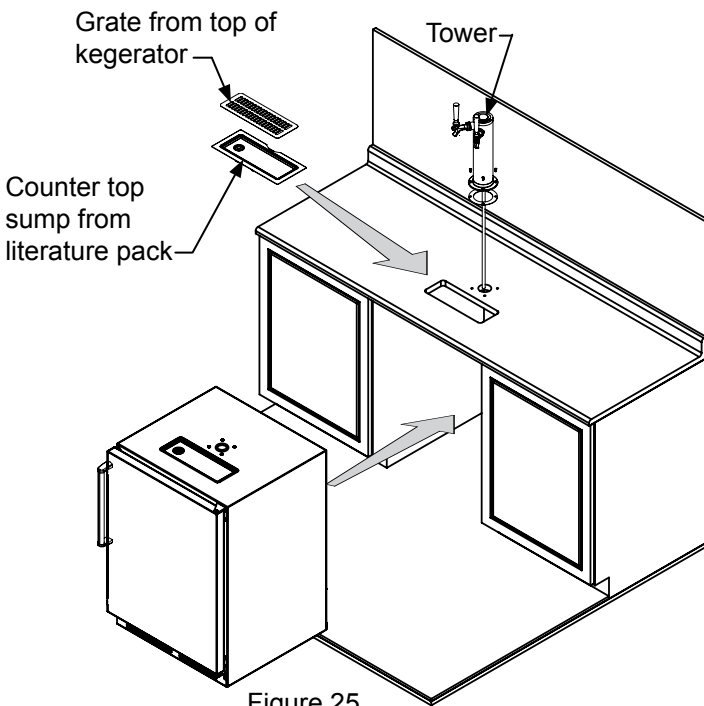

Figure 25

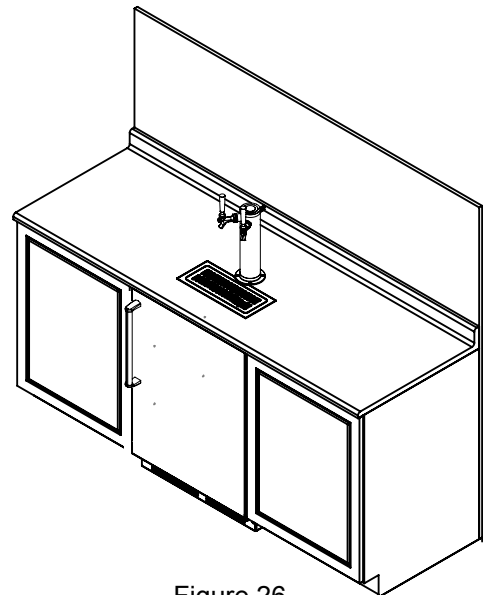

Figure 26

USING YOUR KEGERATOR

9. Hooking up the keg coupler to the keg: Verify the coupler is in the "OFF" position (see Figure 28a). Align the lugs on the keg with the corresponding openings on the keg coupler and turn clockwise until the coupler stops (about 90°). Push down and twist the top of the coupler clockwise to allow gas to enter the keg.

Push faucet handle back toward tower to close the faucet

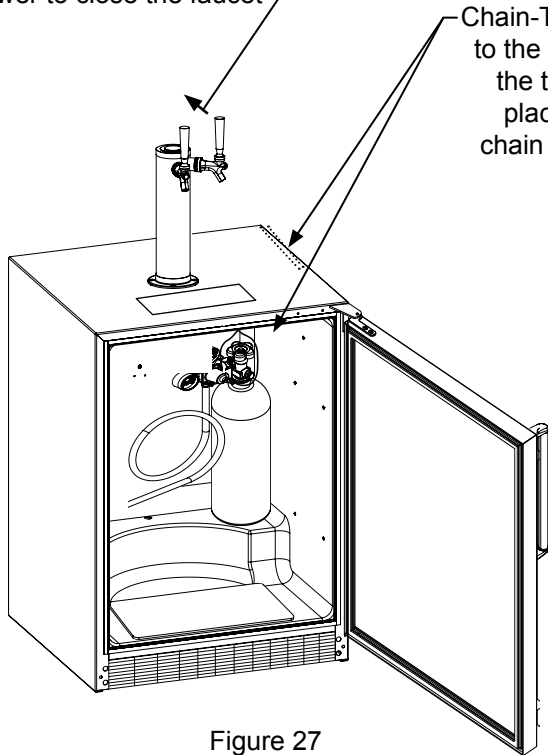

Figure 27

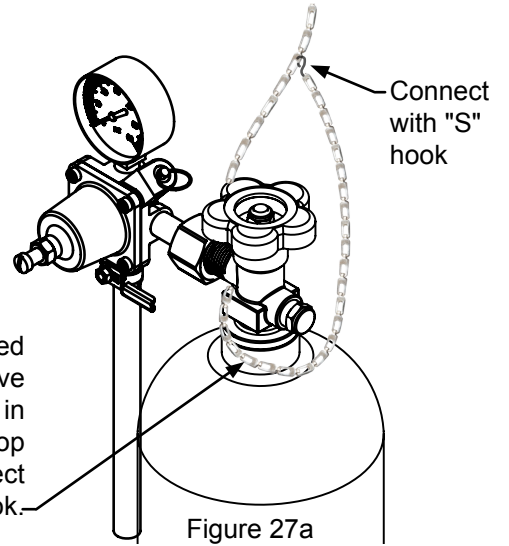

Figure 27a

Rotate the top of the coupler counter clockwise to extend the coupler to the "OFF" position.

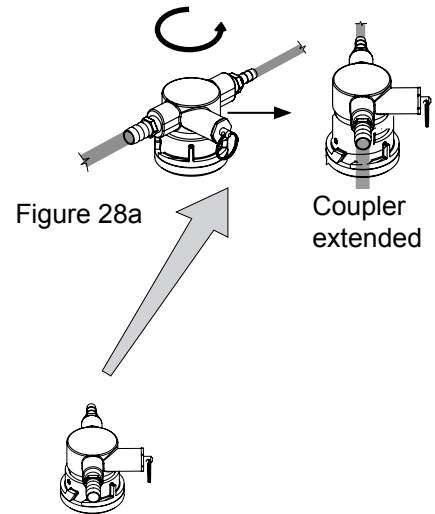

Figure 28a

Lugs on keg



Figure 28b

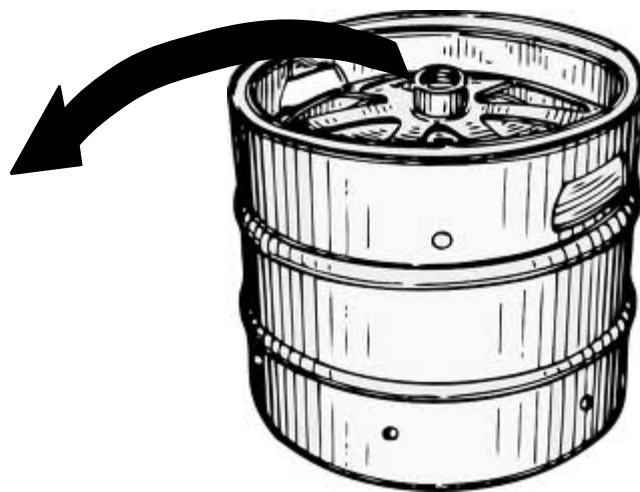

Figure 28

USING YOUR KEGERATOR

CO₂ Regulator (Double Dispense Tower)

Your beer dispenser comes equipped with a 5 pound CO₂ tank and a dual gauge regulator. The lower gauge should be reading approximately 750 psi (52 bar) when the tank is properly filled and the tank is not in the refrigerator (at room temperature). The tank will read less when chilled. Use this lower gauge as an indicator of how much CO₂ you have left in the tank.

The upper gauge reads the pressure being supplied to the beer keg. Follow the procedure below to adjust the pressure to 12 - 14 psi (0.8 to 1 bar) for lager beer or 9 - 12 psi (0.6 to 0.8 bar) for ale's.

To adjust the pressure (Upper Gauge):

1. Close the shutoff valves at the bottom of the regulator.
2. Be sure the faucet handle is closed on the tower (see Figure 31).
3. Loosen the lock nut by turning \curvearrowright counterclockwise using the $\frac{1}{2}$ " open end wrench until loose, this will allow adjustment of the pressure adjustment screw.
4. With the flat bladed screwdriver turn the adjustment screw \curvearrowright clockwise to increase the pressure or \curvearrowleft counterclockwise to decrease the pressure.
5. Open the shutoff valve on the bottom of the regulator. The gauge reading may drop but will return very quickly.
6. Pull the ring on the keg coupler to allow the gas to flow momentarily.
7. Make any fine adjustments if necessary with the adjustment screw.
8. Tighten the locknut with the $\frac{1}{2}$ " open end wrench by turning clockwise \curvearrowright .

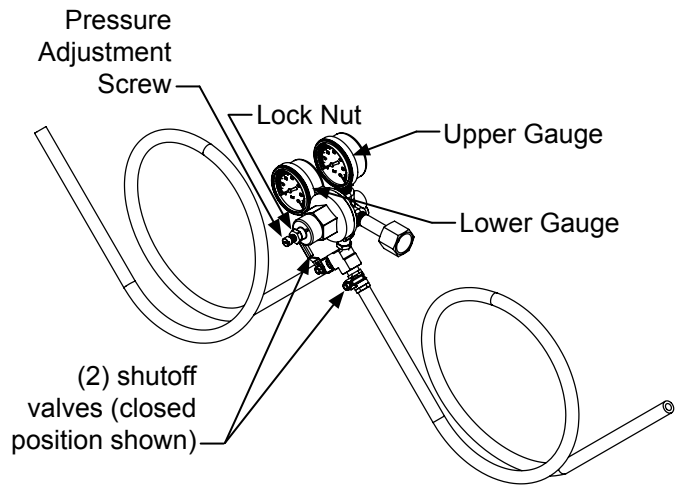

Figure 30 (Regulator for Double Dispense Tower)

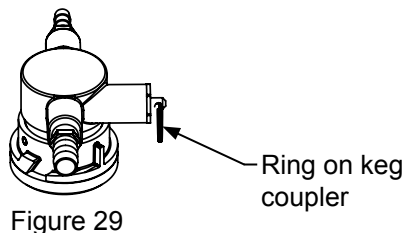

Figure 29

USING YOUR KEGERATOR AND CARE AND CLEANING

Drain kit (All Models): The drain kit is shipped in place and ready to use. **To empty:** Pull drain hose out of bottle cap, remove bottle from unit, unscrew cap and discard waste and rinse bottle. Reinstall bottle in unit.

Cleaning the drain sump:

On a **free standing kegerator** remove the grate from in front of the tower, clean with soap and water and dry before reinstalling. Clean the sump area with soapy water and dry. (See figure 31).

On a **built in kegerator** remove the grate and counter top sump, clean with soap and water and dry before reinstalling. Clean the sump area with soapy water and dry. (See Figure 32).

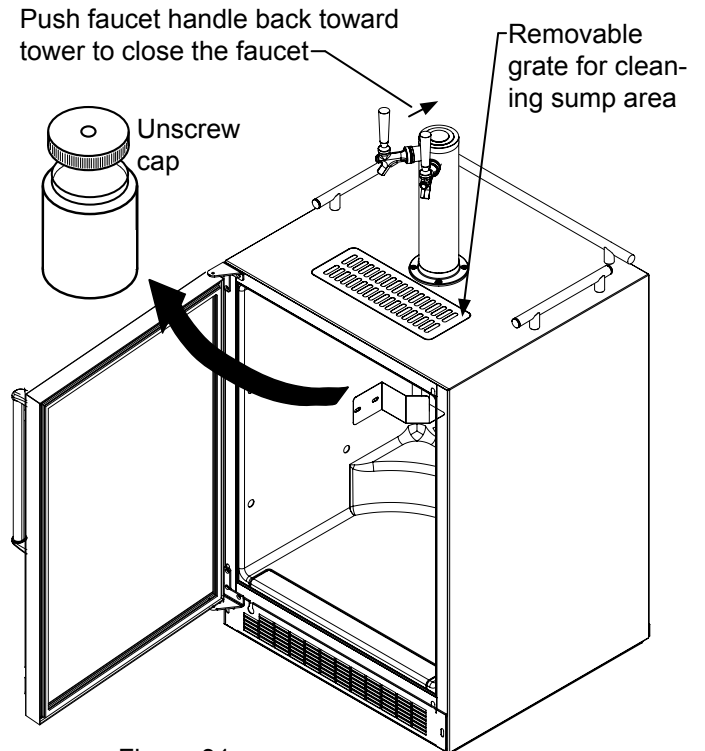

Figure 31

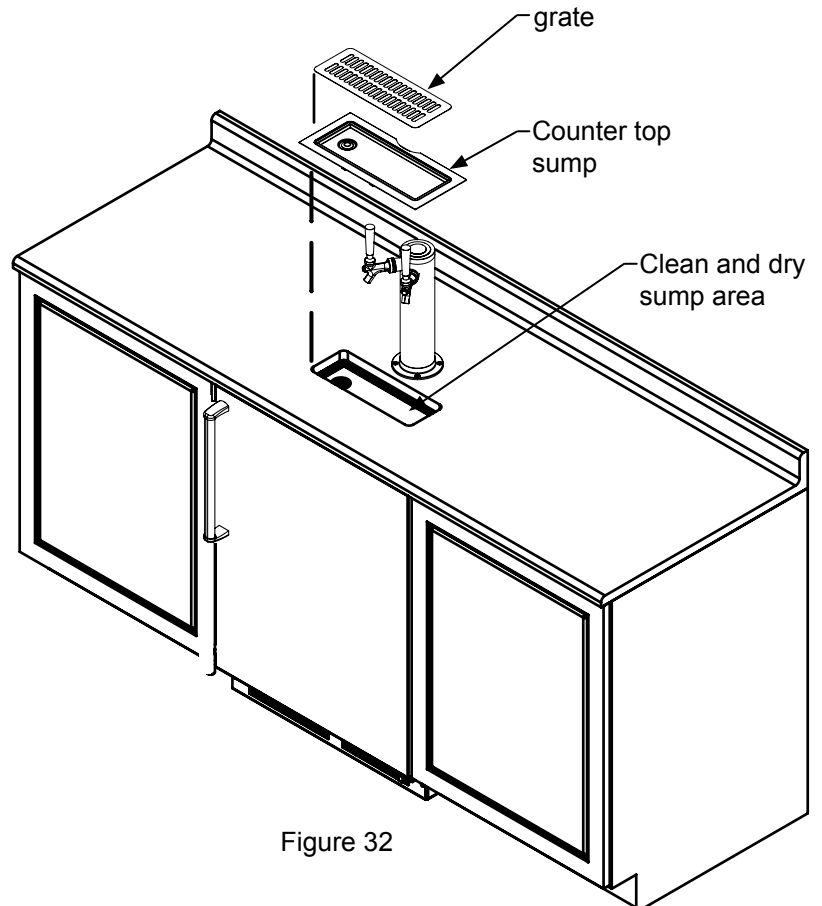

Figure 32

CARE AND CLEANING

Cleaning and Maintaining Dispensing System

The dispensing system needs to be cleaned between usage to prevent spoilage and/or foul taste in your beer.

Keg Coupler Cleaning

Remove the keg coupler from the keg if necessary. Close the gas valve below the regulator, remove both the red gas line and clear beer line from the keg coupler by removing the plastic hose clamps (See Figure 33). Soak and brush the keg coupler in hot water or a sanitizing solution. Rinse thoroughly with clean water. Dry all parts and reassemble.

Hose clamps can be released by a lateral movement to the head.

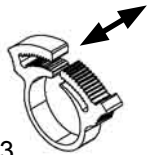

Figure 33

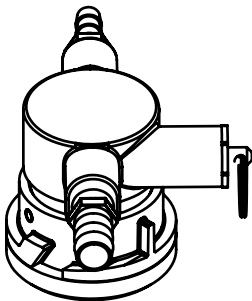
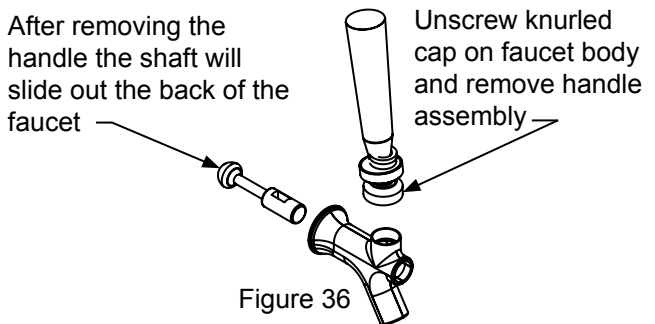
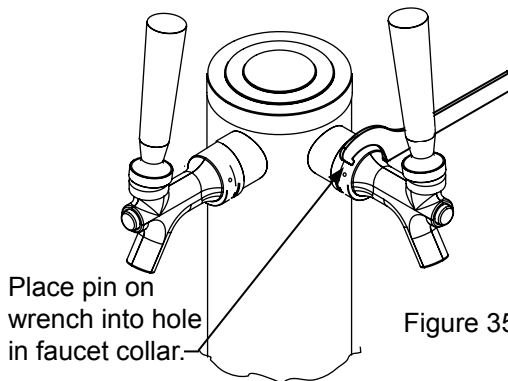

Figure 34

Faucet Cleaning

Turn off the gas supply with the shutoff valve under the regulator (see Figure 31) and open the faucet to relieve the pressure. To remove the faucet from the tower use the spanner wrench provided. Place the pin on the wrench into the hole on the faucet collar and turn clockwise \curvearrowright to remove the faucet. (See Figure 35).

Remove the knurled cap from the faucet body just below the handle and pull the handle assembly from the faucet. This will allow the shaft to be removed from the back of the faucet, see Figure 36.



Soak all faucet parts in hot clear water or a solution of hot water and a sanitizing solution. Do not use soap. Rinse thoroughly with clean water.

Reassemble faucet, assemble faucet to tower (be sure faucet is in off position), and turn on gas valve.

CARE AND CLEANING

Tap Cleaning Kit

This is an optional item (part number 3594-CK) Kit includes everything to quickly clean tap. Includes cleaning solution, pump, mixing bottle, brush and wrench.

Cleaning the beer line (using tap cleaning kit 3594-CK):

With the faucet removed from the tower (see page 17) and the keg coupler removed from the keg (see page 17), place the end of the beer line in a pail or pan. Secure a pump to the tower with the coupler nut provided on the pump assembly. Pump a sanitizer / cleaner through the beer line until clean. Rinse the pump bottle with hot water, and using the pump, flush the beer line 2 or 3 times with clean hot water.

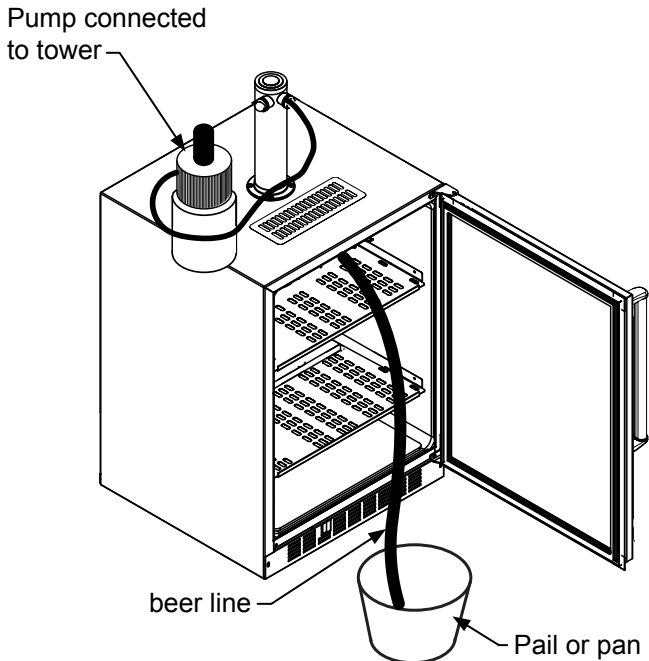

Figure 37

Front Grille

Be sure that nothing obstructs the required air flow openings in front of the cabinet. At least once or twice a year, brush or vacuum lint and dirt from the front grille area (see page 4).

CAUTION

SHOCK HAZARD: Disconnect electrical power from the appliance before cleaning with soap and water.

Cabinet

The stainless steel cabinet can be washed with either a mild soap and water and thoroughly rinsed with clear water. NEVER use abrasive scouring cleaners. Dry thoroughly with a terry towel.

Interior

Wash interior compartment with mild soap and water. Do NOT use an abrasive cleaner, solvent, polish cleaner or undiluted detergent.

Care of Appliance

1. Avoid leaning on the door, you may bend the door hinges or tip the appliance.
2. Exercise caution when sweeping, vacuuming or mopping near the front of the appliance. Damage to the grille can occur.
3. Periodically clean the interior of the appliance as needed.

In the Event of a Power Failure

If a power failure occurs, try to correct it as soon as possible. Minimize the number of door openings while the power is off so as not to adversely affect the appliance's temperature.

CARE AND CLEANING

Long term storage / winterization:

1. Time to Winterize, when the daily low ambient temperature is at or below 38F.

CAUTION

Operating of the unit at ambient temperatures below the recommended Winterization temperature will void your warranty.

2. Turn unit off, (see page 9).
3. Remove all contents.
4. If necessary, move the unit so you can gain access to the rear of the product.
5. Unplug the unit from the power outlet.
6. It is also recommended that the power to the outlet be turned-off if the circuit is not required for other items during the Winter season.
7. Shut-off CO2 tank valve.
8. Drain beer line(s)
 - a. Remove Sankey tap (keg coupler), (see page 17).
 - b. Remove faucet on tower, (see page 17).
 - c. Beer lines will gravity drain.
 - d. Clean beer line tubing, (see page 18).
9. Disassemble faucet and clean, (see page 17).
10. Soak and clean Sankey Low-Boy tap, (see page 17).
11. When cleaning unit pay particular attention to any cracks and crevices that may have accumulated dirt and debris.
12. Remove the front toe-grille, (see Figure 39), and use a brush and vacuum to clean dirt and debris from beneath the unit.
13. Thoroughly clean the toe-grille and re-install on the unit.
14. Remove the rear access cover, (see Figure 40), and use a brush and vacuum to clean dirt and debris from the machine compartment.
 - If the plastic defrost drain pan located under the compressor contains water, use a sponge to remove as much water as possible
15. Thoroughly clean the rear access cover and re-install on the unit.
16. Wipe down all interior surfaces with anti-bacterial cleaner to be followed with clean rinse water to remove any residual chemicals which could cause staining. Do not use any abrasive cleaners or scouring pads.
 - Remove plastic floor protector and stainless steel lower edge guard to clean underneath.

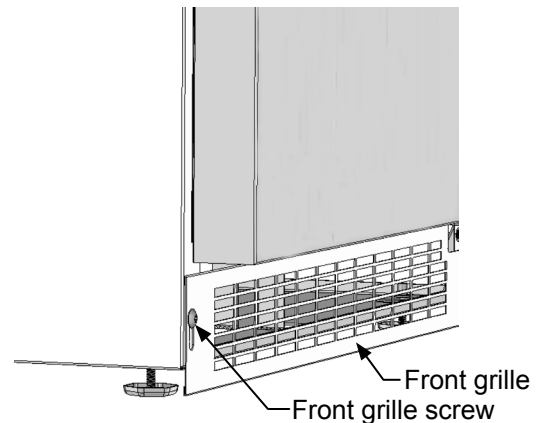

Figure 38

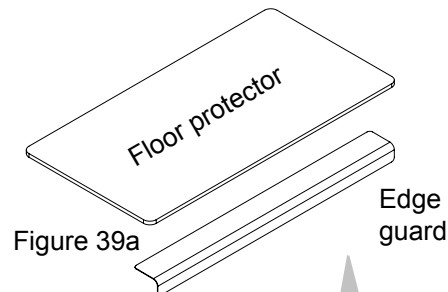

Figure 39a

Remove floor protector and edge guard and clean

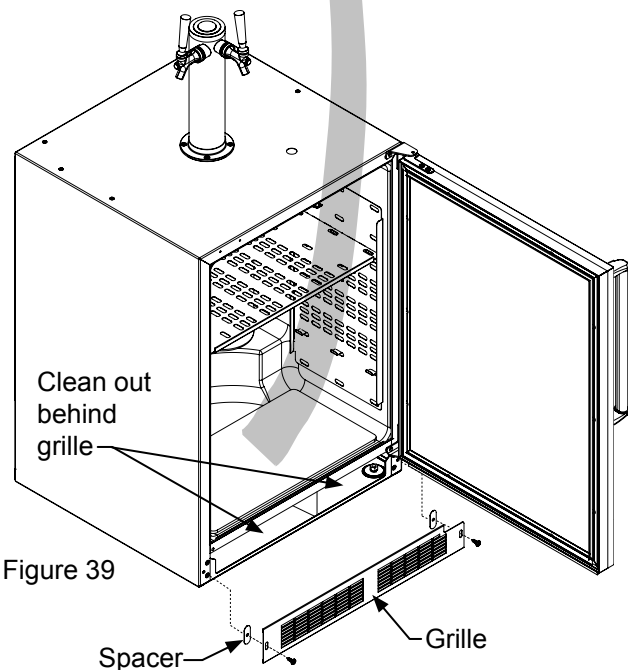
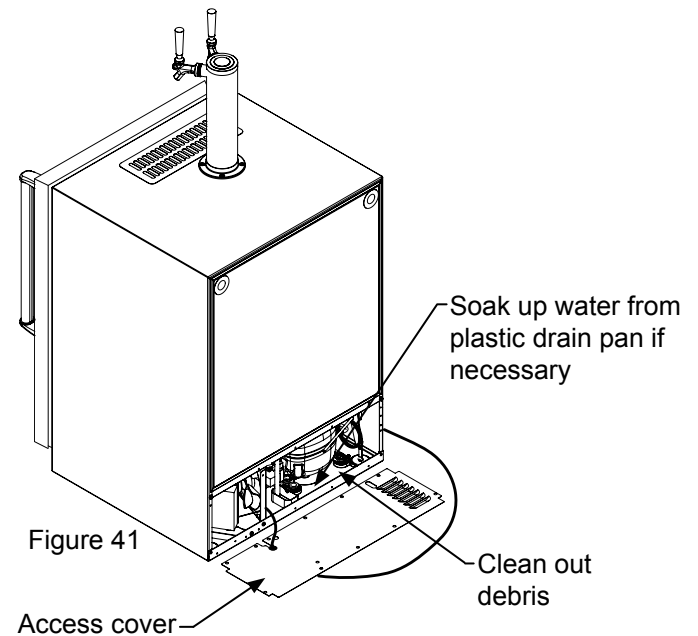
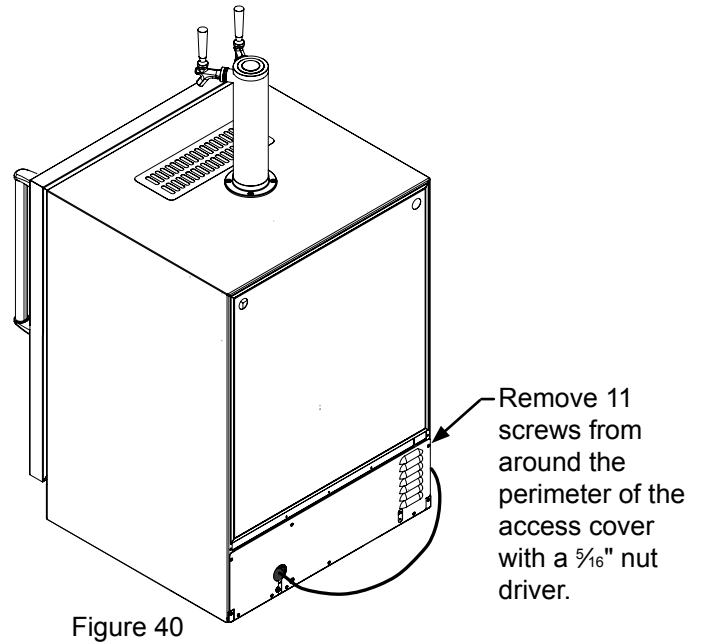

Figure 39

CARE AND CLEANING

17. Leave door open and allow to completely dry out before closing door.
18. Thoroughly clean the door gasket with anti-bacterial cleaner to be followed with clean rinse water to remove any residual chemicals.
19. Thoroughly clean the exterior with a cleaner approved for stainless steel . Do not use any abrasive cleaners or scouring pads.
20. Any mounting hardware / fasteners that are showing signs of corrosion should be replaced.
21. Once the exterior has been thoroughly cleaned, you may want to apply a coating of car wax to help protect against spotting from moisture, dirt, and debris that may accumulate on the surfaces during the Winterization period.
22. Do not place a cover on the unit, as this can trap condensation.

After completion of the above, you may choose to store the unit indoors, although this is not required.



Start-Up After Long-Term Storage:

1. Connect the unit to electrical power.
2. If stored outside, it is recommended that the unit again be thoroughly inspected per the storage instructions above to address any dirt or debris from the weather and/or animals/insects.
3. Turn unit on and confirm your desired control settings.
4. Allow 24-hrs for the unit to stabilize before loading contents.

STAINLESS STEEL MAINTENANCE AND ENERGY SAVING TIPS

Background

Stainless steel does not stain, corrode, or rust as easily as ordinary steel, but it is not stain or corrosion proof. Stainless steels can discolor or corrode if not maintained properly.

Stainless steels differ from ordinary carbon steels by the amount of chromium present. It is this chromium that provides an invisible protective film on the surface called chrome-oxide. This protective chrome-oxide film on the surface can be damaged or contaminated, which may result in discoloration, staining, or corrosion of the base metal.

Care & Cleaning

Routine cleaning of the stainless steel surfaces will serve to greatly extend the life of your product by removing contaminants. This is especially important in coastal areas which can expose the stainless to severe contaminants such as halide salts, (sodium chloride).

It is strongly recommended to periodically inspect and thoroughly clean crevices, weld points, under gaskets, rivets, bolt heads, and any locations where small amounts of liquid could collect, become stagnant, and concentrate contaminants. Additionally, any mounting hardware that is showing signs of corrosion should be replaced.

Frequency of cleaning will depend upon the installation location, environmental, and usage conditions.

Choosing a Cleaning Product

The choice of a proper cleaning product is ultimately that of the consumer, and there are many products from which to choose. Depending upon the type of cleaning and the degree of contamination, some products are better than others.

Typically the most effective and efficient means for routine cleaning of most stainless steel products is to give the surfaces a brisk rubbing with a soft cloth soaked in warm water and a gentle detergent, or mild mixture of ammonia. Rubbing should, to the extent possible, follow the polish lines of the steel, and always insure thorough rinsing after cleaning.

Although some products are called "stainless steel cleaners," some may contain abrasives which could scratch the surface, (compromising the protective chrome-oxide film), and some many contain chlorine bleach which will dull, tarnish or discolor the surface if not completely removed.

After the stainless surfaces have been thoroughly cleaned, a good quality car wax may be applied to help maintain the finish.

NOTE

Stainless steel products should never be installed, or stored in close proximity to chlorine chemicals.

Whichever cleaning product you chose, it should be used in strict accordance with the instructions of the cleaner manufacturer.

The following suggestions will minimize the cost of operating your refrigeration appliance.

1. Do not install your appliance next to a hot appliance (cooker, dishwasher, etc.), heating air duct, or other heat sources.
2. Install product out of direct sunlight.
3. Ensure the front grille vents at front of appliance beneath door are not obstructed and kept clean to allow ventilation for the refrigeration system to expel heat.
4. Plug your appliance into a dedicated power circuit. (Not shared with other appliances).
5. When initially loading your new product, or whenever large quantities of warm contents are placed within refrigerated storage compartment, minimize door openings for the next 12 hours to allow contents to pull down to compartment set temperature.
6. Maintaining a relatively full storage compartment will require less appliance run time than an empty compartment.
7. Ensure door closing is not obstructed by contents stored in your appliance.
8. Allow hot items to reach room temperature before placing in product.
9. Minimize door openings and duration of door openings.
10. Use the warmest temperature control set temperature that meets your personal preference and provides the proper storage for your stored contents.
11. When on vacation or away from home for extended periods, set the appliance to warmest acceptable temperature for the stored contents.
12. Set the control to the "off" position if cleaning the appliance requires the door to be open for an extended period of time.

TROUBLESHOOTING AND OBTAINING SERVICE

Before You Call for Service

If the appliance appears to be malfunctioning, read through this manual first. If the problem persists, check the troubleshooting guide below. Locate the problem in the guide and refer to the cause and its remedy before calling for service. The problem may be something very simple that can be solved without a service call. However, it may be required to contact your dealer or a qualified service technician.



CAUTION

In the unlikely event you lose cooling in your unit, **do not unplug the product from the electric supply**, but do call a qualified service technician immediately. It is possible that the loss of cooling capacity is a result of excessive frost build-up on the evaporator cooling coil. In this case, removing power to the unit will result in the melting of this excessive quantity of ice, which could generate melt water that exceeds the capacity of the defrost drain system and could result in water damage to your home. The end-user will be ultimately responsible for any water damage caused by prematurely turning the unit off without appropriately managing the excess water run-off.



WARNING

Electrocution Hazard

- Never attempt to repair or perform maintenance on the appliance until the main electrical power has been disconnected. Turning the appliance control "OFF" does not remove electrical power from the unit's wiring.
- Replace all parts and panels before operating.

Problem	Possible Cause	Remedy
Appliance not cold enough (See "Adjusting the temperature" on page 9)	<ul style="list-style-type: none"> • Control set too warm • Content temperature not stabilized. 	<ul style="list-style-type: none"> • Adjust temperature colder. Allow 24 hours for temperature to stabilize.
	<ul style="list-style-type: none"> • Excessive usage or prolonged door openings. 	<ul style="list-style-type: none"> • Allow temperature to stabilize for at least 24 hours.
	<ul style="list-style-type: none"> • Airflow to front grille blocked. 	<ul style="list-style-type: none"> • Airflow must not be obstructed to front grille. See "clearances" on page 4.
	<ul style="list-style-type: none"> • Door gasket not sealing properly. 	<ul style="list-style-type: none"> • Replace door gasket.
Appliance too cold (See "Adjusting the Temperature" on page 9)	<ul style="list-style-type: none"> • Control set too cold 	<ul style="list-style-type: none"> • Adjust temperature warmer. Allow 24 hours for temperature to stabilize.
	<ul style="list-style-type: none"> • Door gasket not sealing properly. 	<ul style="list-style-type: none"> • Replace door gasket.
Noise or Vibration	<ul style="list-style-type: none"> • Appliance not level 	<ul style="list-style-type: none"> • Level appliance, see "Leveling Legs" on page 4.
	<ul style="list-style-type: none"> • Fan hitting tube obstruction. 	<ul style="list-style-type: none"> • Contact a qualified service technician.
Appliance will not run.	<ul style="list-style-type: none"> • Appliance turned off 	<ul style="list-style-type: none"> • Turn appliance on. See "Starting your appliance" on page 9.
	<ul style="list-style-type: none"> • Power cord not plugged in. 	<ul style="list-style-type: none"> • Plug in power cord.
	<ul style="list-style-type: none"> • No power at outlet. 	<ul style="list-style-type: none"> • Check house circuit.

WARRANTY

Peterson Fire Magic Limited Warranty

What is covered and for how long?

This warranty covers all defects in workmanship or materials for a period of:

12 months parts

The warranty commences on the date the item was purchased and the original purchase receipt must be presented to the authorized service center before warranty repairs are rendered.

What is covered?

The mechanical and electrical parts, which serve as a functional, purpose of this appliance for a period of 12 months. This includes all parts except finish, and trim.

What will be done?

1. We will repair or replace, at our discretion any mechanical or electrical part which proves to be defective in normal usage during the warranty period so specified.
2. There will be no charge to the purchaser for parts on any covered items during the initial 12 month period.
3. This warranty does not cover labor or labor related charges, except as provided by separate specific written programs from the Peterson Co. All repair work must be performed by a qualified professional service person and requires prior approval of Peterson.
4. Contact your nearest authorized Fire Magic Dealer. For the name of the nearest Fire Magic Dealer please call 1-626-369-5085.

THIS WARRANTY DOES NOT COVER THE FOLLOWING:

Damages from improper installation.
Damages in shipping.
Defects other than manufacturing.
Damage from misuse, abuse, accident, alteration, lack of proper care and maintenance or incorrect current or voltage.
Damage from other than household use.
Damage from service by other than an authorized dealer or service center. Decorative trims or replaceable light bulbs.
Transportation and shipping.

THIS LIMITED WARRANTY IS GIVEN IN LIEU OF ALL OTHER WARRANTIES, EXPRESSED OR, INCLUDING THE WARRANTIES OF MERCHANTABILITY AND FITNESS FOR A PARTICULAR PURPOSE.

The remedy provided in this warranty is exclusive and is granted in lieu of all other remedies.

This warranty does not cover incidental or consequential damages, so the above limitations may not apply to you. Some States do not allow limitations on how long an implied warranty lasts, so the above limitations may not apply to you. This warranty gives you specific legal rights, and you may have other rights, which vary, from state to state.

Fire Magic
14724 East Proctor Ave
City of Industry, CA 91746

